



## Product Data

### **EVERGREEN® 19XR,XRV High-Efficiency Hermetic Centrifugal Liquid Chiller 50/60 Hz HFC-134a**

19XR — 200 to 1500 Nominal Tons (703 to 5275 kW)  
19XRV — 200 to 1500 Nominal Tons (703 to 5275 kW)

# Evergreen® CHILLERS

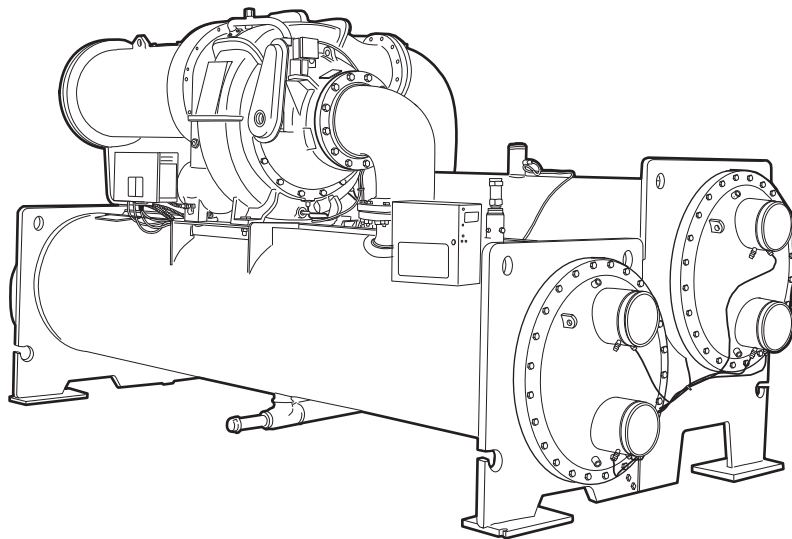

19XR,XRV

Carrier's Evergreen® centrifugal chillers offer:

- The use of non-ozone depleting refrigerant HFC-134a, which is not affected by scheduled refrigerant phaseouts
- An annual leak rate of 0.1%, the lowest published in the industry
- The ability to store the entire charge of refrigerant inside the chiller, minimizing the chance of leaks during refrigerant transfer for maintenance
- Hermetic compression
- Refrigerant-cooled VFD (variable frequency drive) (19XRV only)
- Modular construction
- Positive pressure design

## Features/Benefits

**The Carrier-designed Evergreen family of chillers achieve superior efficiencies without compromising the environment.**

The Evergreen chillers superior efficiencies are obtained at true operating conditions. Therefore, the effects of potential direct or indirect global warming are greatly diminished.

### **High efficiency**

Today's owners of chilled water plants demand high efficiency from their chillers. Per AHRI 550/590, chillers operate at design conditions less than one percent of the time. As a result, superior part load efficiency is required for today's chilled water applications.

# Features/Benefits (cont)



The Evergreen® 19XRV centrifugal chiller, equipped with a factory-installed variable speed drive, maximizes chiller efficiency by optimizing compressor operation. Electric power consumption drops dramatically when the motor speed slows. The 19XRV chiller delivers industry-leading integrated part load values (IPLV).

## Environmental leadership

Carrier has long been committed to the environment and its sustainability. Evergreen chillers provide our customers with a high-efficiency, chlorine-free long-term solution unaffected by refrigerant phaseouts. Carrier's decision to utilize non-ozone depleting HFC-134a refrigerant provides our customers with a safe and environmentally sound choice without compromising efficiency.

## Reliability

The Evergreen chiller's simple, single-stage positive-pressure compressor, coupled with ASME-constructed heat exchangers, ensures superior reliability and sustainability. Carrier's hermetic motors operate in a clean-liquid, refrigerant-cooled environment. The hermetic design eliminates the potential for shaft seal leaks and refrigerant/oil loss. These are just some of the reasons why the Evergreen family of chillers has the industry's lowest leak rate.

## Positive pressure design

The Evergreen chiller's positive pressure design reduces the chiller size by up to 35% compared to low-pressure designs. The smaller size minimizes the need for valuable mechanical room floor space. In addition, positive pressure designs eliminate the need for costly low-pressure containment devices, reducing the initial cost of the system.

## The Evergreen chiller advantage

The Evergreen chiller can be shipped fully charged, minimizing start-up and maintenance time. Purge units are not required. The tight construction of the Evergreen centrifugal chiller ensures that contaminants stay out and efficiency is maintained throughout the life of the chiller.

## Modular construction

The cooler, condenser, and compressor assemblies are completely bolted

together, making the Evergreen chillers ideally suited for replacement projects where ease of disassembly and reassembly at the jobsite are essential.

## Marine container shipment (19XR, heat exchanger frame sizes 1 to 6 only)

The compact design allows for open-top container shipment to export destinations, ensuring product quality while reducing shipping cost.

## Optional refrigerant isolation valves

This system allows the refrigerant to be stored inside the chiller during servicing, reducing refrigerant loss and eliminating time-consuming transfer procedures. As a self-contained unit, the Evergreen chillers do not require additional remote storage systems.

## Optional pumpdown unit

Combined with the refrigerant isolation valves listed above, the optional pumpdown unit eliminates complex connections to portable transfer systems, thereby reducing service costs. In addition, the optional pumpdown compressor meets Environmental Protection Agency's (EPA's) vacuum level requirements that mandate minimizing refrigerant emissions during service.

## Optional unit-mounted starter

Available in low-voltage wye-delta and solid state, Carrier's unit-mounted starter provides a single point power connection, reducing chiller installation time and expense. (Available on heat exchanger frame sizes 1 to 7 only.)

## Optional seismic kit

A seismic isolation package is available to meet International Building Code and ASCE 7 seismic qualification requirements in concurrence with ICC ES AC156 Acceptance Criteria for Seismic Qualification by Shake-Table Testing of Nonstructural Components and Systems.

## Hermetic compressor features

**Single-stage design** increases product reliability by eliminating the additional moving parts associated with multiple stage chillers, such as additional guide vanes and complex economizers.

**Aerodynamically contoured impellers** use high back sweep main blades with low-profile intermediate splitter blades. The impellers are aerodynamically contoured to improve compressor full load and part load operating efficiency.

**Tunnel diffuser** design uses jet engine technology, increasing centrifugal compressor peak efficiency.

**Hermetic motors** are hermetically sealed from the machine room; cooling is accomplished by spraying liquid refrigerant on the motor windings. This highly efficient motor cooling method results in the use of smaller, cooler-running motors than could be realized with air-cooled designs of the same type.

In addition, Carrier's hermetic design eliminates:

- Compressor shaft seals that require maintenance and increase the likelihood of refrigerant leaks

# Table of contents

	Page
Features/Benefits . . . . .	1-4
Model Number Nomenclature . . . . .	5
Chiller Components . . . . .	6,7
Physical Data . . . . .	8-18
Options and Accessories . . . . .	19,20
Dimensions . . . . .	21-23
Selection Procedure . . . . .	23
Electrical Data . . . . .	24
Controls . . . . .	25-27
Typical Piping and Wiring . . . . .	28,29
Application Data . . . . .	30-39
Guide Specifications . . . . .	40-48

- Shaft alignment problems that occur with open-drive designs during start-up and operation, when equipment temperature variations cause thermal expansion
- High noise levels that are common with air-cooled motors, which radiate noise to the machine room and adjacent areas
- Machine room cooling requirements associated with air-cooled motors, which dissipate heat to the machine room

**Compressors are 100% run-tested** to ensure proper operation of all compressor systems, including oil management, vibration, electrical, power transmission, and compression.

### Heat exchanger features

**The American Society of Mechanical Engineers (ASME) standard** requires the use of an independent agency to certify the design, manufacture, and testing of all heat exchangers, ensuring the ultimate in heat exchanger safety, reliability, and long life.

**Refrigerant-cooled VFD (19XRV)** minimizes VFD size and ensures proper cooling of the transistors for extended life. Using R-134a refrigerant instead of water also eliminates costly maintenance associated with the water cooling pump, heat exchanger and rubber tubing used with water-cooled VFDs.

**Cooler tube expansion** at center support sheets prevents unwanted tube movement and vibration, thereby reducing the possibility of premature tube failure.

**Double-grooved tube sheet holes** eliminate the possibility of leaks between the water and refrigerant system, increasing product reliability.

**Condenser baffle** prevents direct impingement of high velocity compressor gas onto the condenser tubes. The baffle eliminates the related vibration and wear of the tubes and distributes the refrigerant flow evenly over the length of the vessel for improved efficiency.

**Closely spaced intermediate support sheets** prevent tube sagging and vibration, thereby increasing heat exchanger life.

**Refrigerant filter drier isolation valves** allow filter replacement without pumping down the chiller, which means less service time and less expense.

**FLASC (Flash subcooler)**, located in the bottom of the condenser, increases the refrigeration effect by cooling the condensed liquid refrigerant to a lower temperature; the result is reduced compressor power consumption.

**AccuMeter™ system** regulates refrigerant flow according to load conditions, providing a liquid seal at all operating conditions and eliminating unintentional hot gas bypass.

### Microprocessor control features

**Direct digital Product Integrated Control (PIC II)** provides unmatched flexibility and functionality. Each unit integrates directly with the Carrier Comfort Network® (CCN) system, providing a system solution to controls applications.

**International Chiller Visual Control (ICVC)** which can be configured to display units in English or metric, provides unparalleled ease of operation.

A 1/4 VGA 320 x 240 element LCD (liquid crystal display) features 4 menu-specific softkeys. The default display offers all in one glance review of key chiller operation data, simplifying the interaction between chiller and user.

Features include:

- Display of over 125 operating, status, and diagnostic messages for improved user interface
- Monitoring of over 100 functions and conditions to protect the chiller from abnormal conditions
- Modular pull-out/plug-in design, reducing wiring requirements and providing easy installation
- Low-voltage (24 v) design, providing the ultimate assurance of personal safety and control integrity

The display modes include 4 standard languages:

- English
- Chinese
- Japanese
- Korean

Other languages are available.

**Automatic capacity override** function unloads the compressor whenever key safety limits are approached, increasing unit life.

**Chilled water reset** can be accomplished manually or automatically from the building management system. Reset saves energy when warmer chilled water can be used.

**Demand limiting** feature limits the power draw of the chiller during peak loading conditions. When incorporated into the Carrier Comfort Network® building automation system, a red line command holds chillers at their present capacity and prevents any other chillers from starting. If a load shed signal is received, the compressors are unloaded to avoid high demand charges whenever possible.

**Ramp loading** ensures a smooth pull-down of water loop temperature and prevents a rapid increase in compressor power consumption during the pulldown period.

**Automated controls test** can be executed prior to start-up to verify that the entire control system is functioning properly.

**365-day real time clock** feature allows the operator to program a yearly schedule for each week, weekends, and holidays.

**Occupancy schedules** can be programmed into the controller to ensure that the chiller only operates when cooling is required.

**Extensive service menu** features include password protection to prevent unauthorized access to the service menu and built-in diagnostic capabilities assist in troubleshooting and recommend proper corrective action for pre-set alarms, resulting in greater operating time.

**Alarm file** maintains the last 25 time and date-stamped alarm and alert messages in memory; this function reduces troubleshooting time and cost.

**Configuration data backup** in non-volatile memory provides protection during power failures and eliminates time consuming control reconfiguration.

# Features/Benefits (cont)



## 19XR refrigeration cycle

The compressor continuously draws refrigerant vapor from the cooler at a rate set by the amount of guide vane opening. As the compressor suction reduces the pressure in the cooler, the remaining refrigerant boils at a fairly low temperature (typically 38 to 42 F [3 to 6 C]). The energy required for boiling is obtained from the water flowing through the cooler tubes. With heat energy removed, the water becomes cold enough to use in an air-conditioning circuit or process liquid cooling.

After taking heat from the water, the refrigerant vapor is compressed. Compression adds still more heat energy and the refrigerant is quite warm (typically 98 to 102 F [37 to 40 C]) when it is discharged from the compressor into the condenser.

Relatively cool (typically 65 to 90 F [18 to 32 C]) water flowing into the condenser tubes removes heat from the refrigerant, and the vapor condenses to liquid.

The liquid refrigerant passes through orifices into the FLASC (flash subcooler) chamber. Since the FLASC chamber is at a lower pressure, part of the liquid refrigerant flashes to vapor, thereby cooling the remaining liquid. The FLASC vapor is recondensed on the tubes which are cooled by entering condenser water. The liquid drains into a float valve chamber between the FLASC chamber and cooler. Here, the AccuMeter™ float valve forms a liquid seal to keep FLASC chamber vapor from entering the cooler. When liquid refrigerant passes through the valve, some of it flashes to vapor in the reduced pressure on the cooler side. In flashing, it removes heat from the remaining liquid. The refrigerant is now at a temperature and pressure at which the cycle began. Refrigerant from the condenser also cools the oil and optional variable speed drive.

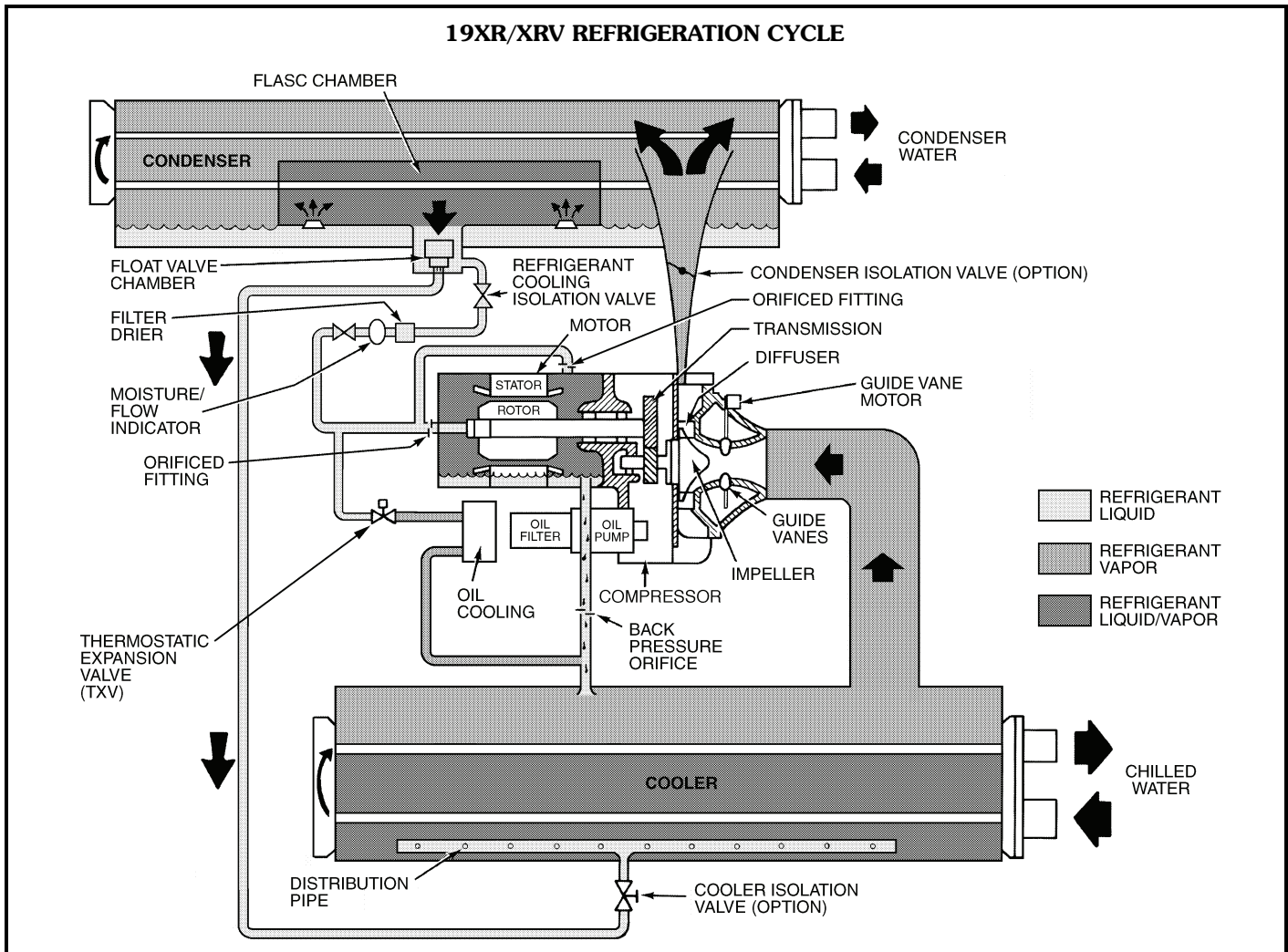

# Model number nomenclature

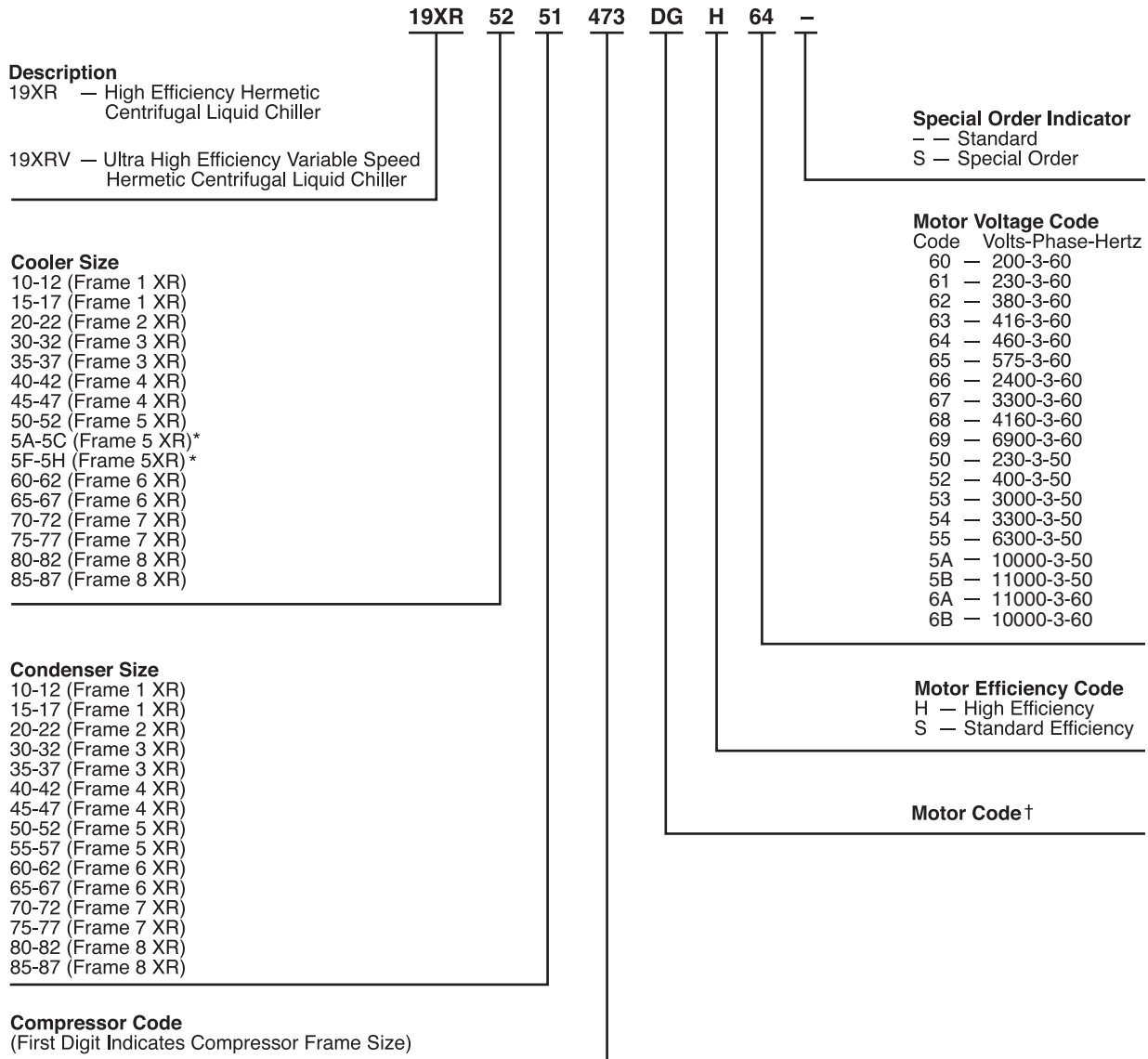

ASME  
'U' Stamp



Water-Cooled Chillers  
AHRI Standard 550/590  
AHRI (Air Conditioning, Heating,  
and Refrigeration Institute)  
Performance Certified

\*Refer to 19XR, 19XRV Computer Selection Program for details on these sizes.

†Refer to the 19XR, 19XRV Computer Selection Program for motor code details.

SEISMICOMPLIANT\*

\* Meets IBC 2006, ASCE-7-05, CBC 2007, and OSHPD seismic requirements.

## COMPRESSOR COMPONENTS

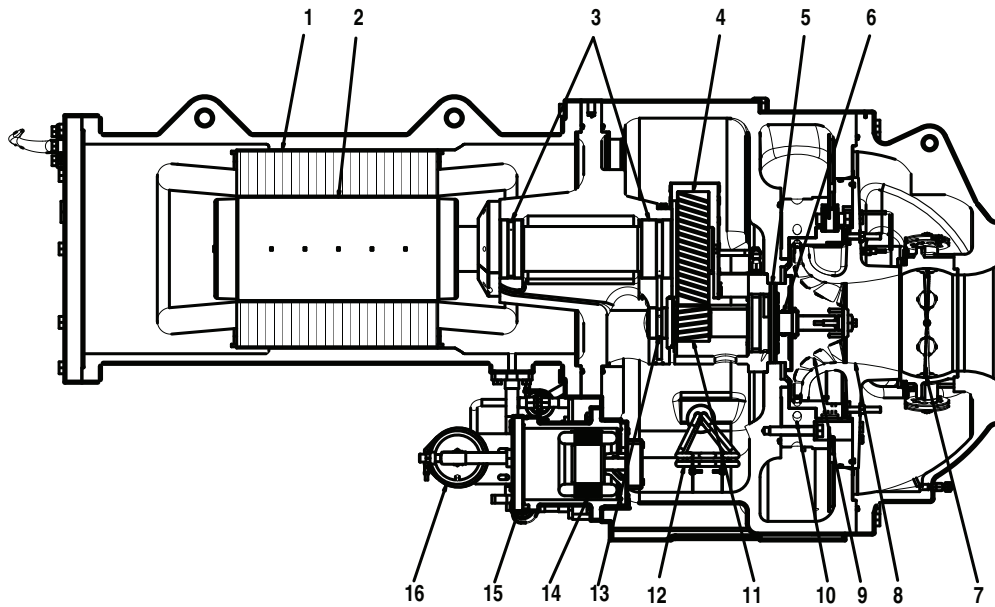

### LEGEND

- |                                     |                               |
|-------------------------------------|-------------------------------|
| 1 — Motor Stator                    | 9 — Impeller                  |
| 2 — Motor Rotor                     | 10 — Pipe Diffuser            |
| 3 — Motor Shaft Journal Bearings    | 11 — High Speed Pinion Gear   |
| 4 — Low Speed Bull Gear             | 12 — Oil Heater               |
| 5 — High Speed Shaft Thrust Bearing | 13 — High Speed Shaft Bearing |
| 6 — High Speed Shaft Bearing        | 14 — Oil Pump Motor           |
| 7 — Variable Inlet Guide Vanes      | 15 — Oil Pump Cover           |
| 8 — Impeller Shroud                 | 16 — Oil Filter               |

**19XR/XRV**

**FRONT VIEW**

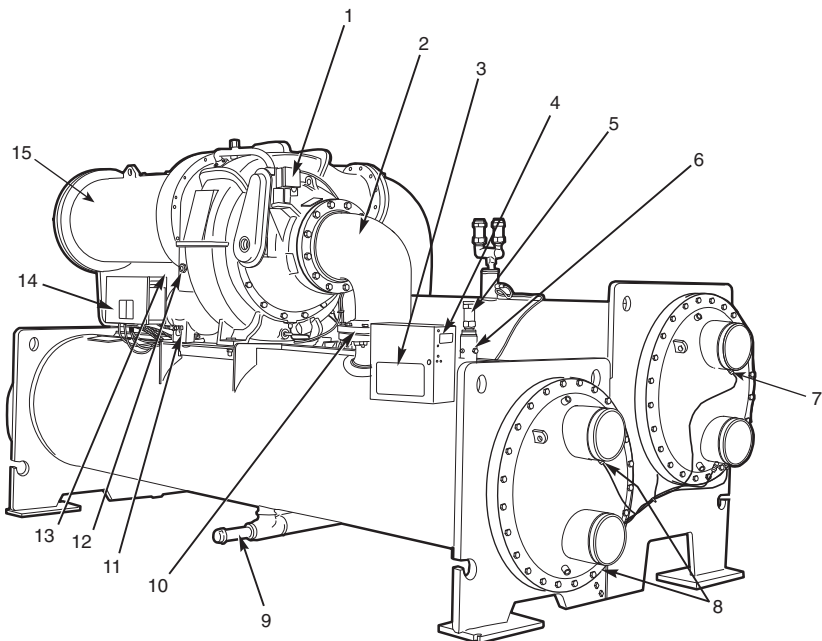

**LEGEND**

- 1 — Guide Vane Actuator
- 2 — Suction Elbow
- 3 — International Chiller Visual Control (ICVC)
- 4 — Chiller Identification Nameplate
- 5 — Cooler, Auto Reset Relief Valves
- 6 — Cooler Pressure Transducer
- 7 — Condenser In/Out Temperature Thermistors
- 8 — Cooler In/Out Temperature Thermistors
- 9 — Refrigerant Charging Valve
- 10 — Typical Flange Connection
- 11 — Oil Drain Valve
- 12 — Oil Level Sight Glasses
- 13 — Refrigerant Oil Cooler (Hidden)
- 14 — Auxiliary Power Panel
- 15 — Motor Housing

**REAR VIEW**

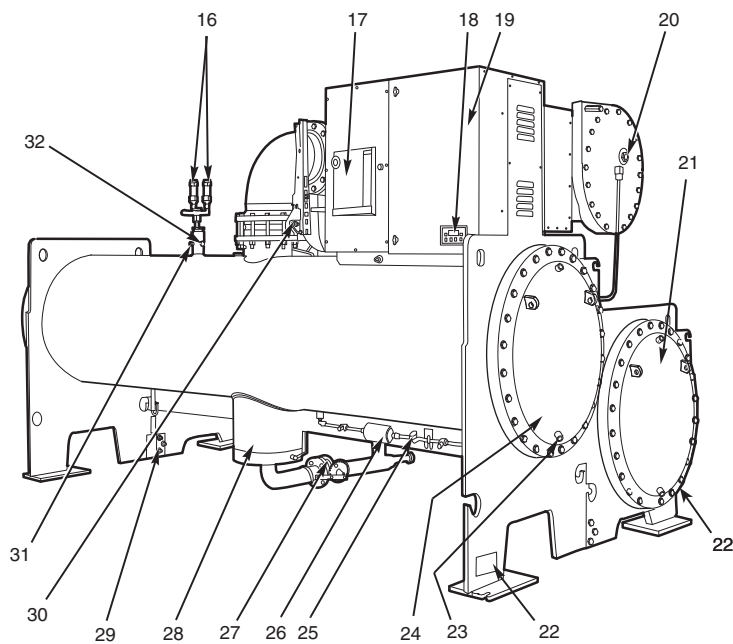

**LEGEND**

- 16 — Condenser Auto. Reset Relief Valves
- 17 — Motor Circuit Breaker
- 18 — Solid-State Starter Control Display
- 19 — Unit-Mounted Starter or VFD (Optional)  
Solid-State Starter Shown
- 20 — Motor Sight Glass
- 21 — Cooler Return-End Waterbox Cover
- 22 — ASME Nameplate (One Hidden)
- 23 — Typical Waterbox Drain Port
- 24 — Condenser Return-End Waterbox Cover
- 25 — Refrigerant Moisture/Flow Indicator
- 26 — Refrigerant Filter/Drier
- 27 — Liquid Line Isolation Valve (Optional)
- 28 — Liquid Float Valve Chamber
- 29 — Vessel Take-Apart Connector
- 30 — Discharge Isolation Valve (Optional)
- 31 — Pumpout Valve
- 32 — Condenser Pressure Transducer

# Physical data



## 19XR COMPRESSOR AND MOTOR WEIGHTS\*— STANDARD AND HIGH EFFICIENCY MOTORS

### COMPRESSOR FRAME SIZE 2†, LOW VOLTAGE MOTORS

MOTOR SIZE	ENGLISH						SI					
	Compressor Weight** (lb)	Stator Weight†† (lb)		Rotor Weight (lb)		End Bell Cover (lb)	Compressor Weight** (kg)	Stator Weight (kg)		Rotor Weight (kg)		End Bell Cover (kg)
		60 Hz	50 Hz	60 Hz	50 Hz			60 Hz	50 Hz	60 Hz	50 Hz	
BD	2300	1014	1014	240	255	182	1044	460	460	109	116	83
BE	2300	1053	1053	252	273	182	1044	478	478	114	124	83
BF	2300	1096	1102	266	294	182	1044	498	500	121	133	83
BG	2300	1160	1160	289	311	182	1044	527	527	131	141	83
BH	2300	1160	1198	289	328	182	1044	527	544	131	149	83
BJ	2300	1198	—	328	—	182	1044	544	—	149	—	83
JB	2300	1003	1063	226	248	—	1043	455	482	103	112	—
JC	2300	1063	1113	248	263	—	1043	482	505	112	119	—
JD	2300	1113	1149	263	278	—	1043	505	521	119	126	—
JE	2300	1149	1196	278	295	—	1043	521	542	126	134	—
JF	2300	1196	—	295	—	—	1043	542	—	134	—	—

### COMPRESSOR FRAME SIZE 3†, LOW AND MEDIUM VOLTAGE MOTORS

MOTOR SIZE	ENGLISH						SI					
	Compressor Weight** (lb)	Stator Weight†† (lb)		Rotor Weight (lb)		End Bell Cover (lb)	Compressor Weight** (kg)	Stator Weight†† (kg)		Rotor Weight (kg)		End Bell Cover (kg)
		60 Hz	50 Hz	60 Hz	50 Hz			60 Hz	50 Hz	60 Hz	50 Hz	
KB	2816	965	995	221	229	274	1278	438	452	100	104	124
KC	2816	995	1015	229	236	274	1278	452	461	104	107	124
KD	2816	1015	1045	236	244	274	1278	461	474	107	111	124
KE	2816	1045	1065	244	251	274	1278	474	484	111	114	124
KF	2816	1065	1090	251	259	274	1278	484	495	114	118	124
KG	2816	1090	1110	259	267	274	1278	495	504	118	121	124
CD	2816	1220	1238	288	313	274	1278	554	562	131	142	124
CE	2816	1253	1285	305	330	274	1278	569	583	138	150	124
CL	2816	1261	1328	305	346	274	1278	572	603	138	157	124
CM	2816	1321	1380	313	363	274	1278	600	627	142	165	124
CN	2816	1369	1423	330	379	274	1278	622	646	150	172	124
CP	2816	1411	1444	346	387	274	1278	641	656	157	176	124
CQ	2816	1419	1522	363	387	274	1278	644	691	165	176	124
CR	2816	1522	—	346	—	274	1278	691	—	157	—	124

\*Total compressor weight is the sum of the compressor aerodynamic components (compressor weight column), stator, rotor, and end bell cover weights.

†Compressor size number is the first digit of the compressor code. See Model Number Nomenclature on page 5.

\*\*Compressor aerodynamic component weight only. Does not include motor weight.

††Stator weight includes the stator and shell.

\*\*\*For high-voltage motors, add the following: 300 lb (136 kg) to stator, 150 lb (68 kg) to rotor, and 40 lb (18 kg) to end bell.

NOTE: Standard-efficiency motor designations are followed by the letter S (e.g., BDS); high-efficiency motor designations are followed by the letter H (e.g., BDH). See Model Number Nomenclature on page 5.



**19XR COMPRESSOR AND MOTOR WEIGHTS\*—  
STANDARD AND HIGH EFFICIENCY MOTORS (cont)**

**COMPRESSOR FRAME SIZE 4†, LOW AND MEDIUM VOLTAGE MOTORS\*\*\***

MOTOR SIZE	ENGLISH						SI					
	Compressor Weight** (lb)	Stator Weight†† (lb)		Rotor Weight (lb)		End Bell Cover (lb)	Compressor Weight** (kg)	Stator Weight†† (kg)		Rotor Weight (kg)		End Bell Cover (kg)
		60 Hz	50 Hz	60 Hz	50 Hz			60 Hz	50 Hz	60 Hz	50 Hz	
LB	3425/4211	1873	1939	364	389	318	1555/1912	850	880	165	177	144
LC	3425/4211	1939	2023	389	406	318	1555/1912	880	918	177	184	144
LD	3425/4211	2023	2043	406	417	318	1555/1912	918	928	184	189	144
LE	3425/4211	2043	2096	417	434	318	1555/1912	928	952	189	197	144
LF	3425/4211	2096	2133	434	444	318	1555/1912	952	968	197	202	144
LG	3425/4211	2133	2199	444	458	318	1555/1912	968	998	202	208	144
LH	3425/4211	2199	—	458	—	318	1555/1912	998	—	208	—	144
DB	3425/4211	1950	1950	406	406	318	1555/1912	885	885	184	184	144
DC	3425/4211	1950	2025	406	429	318	1555/1912	885	919	184	195	144
DD	3425/4211	2150	2250	536	546	318	1555/1912	976	1022	243	248	144
DE	3425/4211	2150	2250	550	550	318	1555/1912	976	1022	250	250	144
DF	3425/4211	2250	2380	575	567	318	1555/1912	1022	1081	261	257	144
DG	3425/4211	2250	2380	599	599	318	1555/1912	1022	1081	272	272	144
DH	3425/4211	2250	2380	604	604	318	1555/1912	1022	1081	274	274	144
DJ	3425/4211	2250	2380	614	614	318	1555/1912	1022	1081	279	279	144
DK	3425/4211	2305	—	614	—	318	1555/1912	1046	—	279	—	144

\*Total compressor weight is the sum of the compressor aerodynamic components (compressor weight column), stator, rotor, and end bell cover weights.

†Compressor size number is the first digit of the compressor code. See Model Number Nomenclature on page 5.

\*\*Compressor aerodynamic component weight only. Does not include motor weight. Weights are for fixed ring/split ring diffusers.

††Stator weight includes the stator and shell.

\*\*\*For high-voltage motors, add the following: 300 lb (136 kg) to stator, 150 lb (68 kg) to rotor, and 40 lb (18 kg) to end bell.

NOTE: Standard-efficiency motor designations are followed by the letter S (e.g., BDS); high-efficiency motor designations are followed by the letter H (e.g., BDH). See Model Number Nomenclature on page 5.

# Physical data (cont)



## 19XR COMPRESSOR MOTOR WEIGHTS\* — STANDARD AND HIGH EFFICIENCY MOTORS (cont)

### COMPRESSOR FRAME SIZE 5†, LOW AND MEDIUM VOLTAGE MOTORS\*\*

MOTOR SIZE	ENGLISH						SI					
	Compressor Weight†† (lb)	Stator Weight*** (lb)		Rotor Weight (lb)		End Bell Cover (lb)	Compressor Weight†† (kg)	Stator Weight*** (kg)		Rotor Weight (kg)		End Bell Cover (kg)
		60 Hz	50 Hz	60 Hz	50 Hz			60 Hz	50 Hz	60 Hz	50 Hz	
EH	7285	3000	3125	810	862	414	3307	1362	1419	368	391	188
EJ	7285	3105	3250	855	862	414	3307	1410	1476	388	391	188
EK	7285	3105	3250	855	872	414	3307	1410	1476	388	396	188
EL	7285	3195	3340	872	872	414	3307	1451	1516	396	396	188
EM	7285	3195	3340	872	914	414	3307	1451	1516	396	415	188
EN	7285	3195	3415	872	974	414	3307	1451	1550	396	442	188
EP	7285	3195	3415	872	974	414	3307	1451	1550	396	442	188
EQ	7285	3203	—	914	—	414	3307	1454	—	415	—	188
MB	7285	2795	2856	645	665	—	3307	1268	1295	293	302	—
MC	7285	2873	2925	672	693	—	3307	1303	1327	305	314	—
MD	7285	2906	3013	684	724	—	3307	1318	1367	310	328	—
ME	7285	2956	3071	704	737	—	3307	1341	1393	319	334	—
MF	7285	3034	3153	724	791	—	3307	1376	1430	328	359	—
MG	7285	3071	—	737	—	—	3307	1393	—	334	—	—

\*Total compressor weight is the sum of the compressor aerodynamic components (compressor weight column), stator, rotor, and end bell cover weights.

†Compressor size number is the first digit of the compressor code. See Model Number Nomenclature on page 5.

\*\*For high-voltage motors, add the following: 300 lb (136 kg) to stator, 150 lb (68 kg) to rotor, and 40 lb (18 kg) to end bell.

††Compressor aerodynamic component weight only. Does not include motor weight.

\*\*\*Stator weight includes the stator and shell.

NOTE: Standard-efficiency motor designations are followed by the letter S (e.g., BDS); high-efficiency motor designations are followed by the letter H (e.g., BDH). See Model Number Nomenclature on page 5.

### COMPONENT WEIGHTS

COMPONENT	FRAME 2 COMPRESSOR*		FRAME 3 COMPRESSOR*		FRAME 4 COMPRESSOR*		FRAME 5 COMPRESSOR*	
	lb	kg	lb	kg	lb	kg	lb	kg
Suction Elbow	116	53	185	84	239	108	407	185
Discharge Elbow	100	45	125	57	157	71	325	147
Control Panel†	34	15	34	15	34	15	34	15
Optional Cooler Inlet Isolation Valve	8	4	13	6	20	9	24	11
Optional Discharge Isolation Valve	26	12	46	21	74	34	108	49
Fixed Front End VFD — 380, 400, and 460-v (230, 335, 445 A)	650	295	650	295	—	—	—	—
Fixed Front End VFD — 380, 400, and 460-v (485, 550 A)	—	—	1035	469	1035	469	—	—
Fixed Front End VFD — 380, 400, and 460-v (605, 680, 765, 855, 960, 1070 A)	—	—	1600	726	1600	726	—	—
Fixed Front End VFD — 380, 400, and 460-v (1275, 1530 A)	—	—	—	—	2800	1270	2800	1270
LiquiFlo 2 VFD — 380, 400, and 460-v (405 A / 608 A)	1600	726	1600	726	1600	726	—	—
LiquiFlo™ 2 VFD — 380, 400, and 460-v (900 A)	—	—	—	—	2800	1270	2800	1270
LiquiFlo 2 VFD — 380, 400, and 460-v (1200 A)	—	—	—	—	2850	1293	2850	1293
LiquiFlo 2 VFD — 575-v (390 A)	2400	1089	2400	1089	—	—	—	—
VFD Shelf	—	—	—	—	1049	476	1049	476

\*To determine compressor frame size, refer to 19XR,XRV Computer Selection Program.

†Included in total cooler weight.



### 19XR HEAT EXCHANGER WEIGHTS

Code	Number of Tubes		English							Metric (SI)					
			Dry Rigging Weight (lb)*		Machine Charge				Dry Rigging Weight (kg)*		Machine Charge				
	Cooler	Condenser	Cooler Only	Condenser Only	Refrigerant Weight (lb)		Water Weight (lb)		Cooler Only	Condenser Only	Refrigerant Weight (kg)		Water Weight (kg)		
					Cooler	Condenser	Cooler	Condenser			Cooler	Condenser	Cooler	Condenser	
10	142	180	2,707	2,704	290	200	283	348	1228	1227	132	91	128	158	
11	161	200	2,777	2,772	310	200	309	374	1260	1257	141	91	140	170	
12	180	225	2,848	2,857	330	200	335	407	1292	1296	150	91	152	185	
15	142	180	2,968	2,984	320	250	327	402	1346	1354	145	113	148	182	
16	161	200	3,054	3,068	340	250	359	435	1385	1392	154	113	163	197	
17	180	225	3,141	3,173	370	250	391	475	1425	1439	168	113	177	215	
20	200	218	3,407	3,373	345	225	402	398	1545	1530	156	102	182	181	
21	240	266	3,555	3,540	385	225	456	462	1613	1606	175	102	207	210	
22	282	315	3,711	3,704	435	225	514	526	1683	1680	197	102	233	239	
30	200	218	4,071	3,694	350	260	464	464	1847	1676	159	118	210	210	
31	240	266	4,253	3,899	420	260	531	543	1929	1769	191	118	241	246	
32	282	315	4,445	4,100	490	260	601	621	2016	1860	222	118	273	282	
35	200	218	4,343	4,606	400	310	511	513	1970	2089	181	141	232	233	
36	240	266	4,551	4,840	480	310	587	603	2064	2195	218	141	266	274	
37	282	315	4,769	5,069	550	310	667	692	2163	2299	249	141	303	314	
40	324	366	4,908	5,039	560	280	863	915	2226	2286	254	127	391	415	
41	364	415	5,078	5,232	630	280	930	995	2303	2373	286	127	422	451	
42	400	464	5,226	5,424	690	280	990	1074	2370	2460	313	127	449	487	
45	324	366	5,363	5,602	640	330	938	998	2433	2541	290	150	425	453	
46	364	415	5,559	5,824	720	330	1014	1088	2522	2642	327	150	460	494	
47	400	464	5,730	6,044	790	330	1083	1179	2599	2742	358	150	491	535	
50	431	507	5,713	6,090	750	400	1101	1225	2591	2762	340	181	499	556	
51	485	566	5,940	6,283	840	400	1192	1304	2694	2850	381	181	541	591	
52	519	602	6,083	6,464	900	400	1248	1379	2759	2932	408	181	566	626	
55	431	507	6,257	6,785	870	490	1201	1339	2838	3078	395	222	545	607	
56	485	566	6,517	7,007	940	490	1304	1429	2956	3178	426	222	591	648	
57	519	602	6,682	7,215	980	490	1369	1514	3031	3273	445	222	621	687	
5A	225	N/A	5,124	N/A	500	N/A	1023	N/A	2324	N/A	227	N/A	464	N/A	
5B	241	N/A	5,177	N/A	520	N/A	1050	N/A	2348	N/A	236	N/A	476	N/A	
5C	258	N/A	5,243	N/A	550	N/A	1079	N/A	2378	N/A	249	N/A	489	N/A	
5F	225	N/A	5,577	N/A	550	N/A	1113	N/A	2530	N/A	249	N/A	505	N/A	
5G	241	N/A	5,640	N/A	570	N/A	1143	N/A	2558	N/A	259	N/A	518	N/A	
5H	258	N/A	5,716	N/A	600	N/A	1176	N/A	2593	N/A	272	N/A	533	N/A	
60	557	648	6,719	6,764	940	420	1400	1521	3048	3068	426	191	635	690	
61	599	695	6,895	6,949	980	420	1470	1597	3128	3152	445	191	667	724	
62	633	741	7,038	7,130	1020	420	1527	1671	3192	3234	463	191	693	758	
65	557	648	7,392	7,682	1020	510	1530	1667	3353	3484	463	231	694	756	
66	599	695	7,594	7,894	1060	510	1610	1753	3445	3581	481	231	730	795	
67	633	741	7,759	8,102	1090	510	1674	1838	3519	3675	494	231	759	834	
70	644	781	9,942	10,782	1220	780	2008	2223	4510	4891	553	354	911	1008	
71	726	870	10,330	11,211	1340	780	2164	2389	4686	5085	608	354	982	1084	
72	790	956	10,632	11,612	1440	780	2286	2544	4823	5267	653	354	1037	1154	
75	644	781	10,840	11,854	1365	925	2183	2429	4917	5377	619	420	990	1102	
76	726	870	11,289	12,345	1505	925	2361	2619	5121	5600	683	420	1071	1188	
77	790	956	11,638	12,803	1625	925	2501	2796	5279	5807	737	420	1134	1268	
80	829	990	12,664	12,753	1500	720	2726	2977	5744	5785	680	327	1236	1350	
81	901	1080	12,998	13,149	1620	720	2863	3143	5896	5964	735	327	1299	1426	
82	976	1170	13,347	13,545	1730	720	3005	3309	6054	6144	785	327	1363	1501	
85	829	990	13,804	14,008	1690	860	2951	3238	6261	6354	767	390	1339	1469	
86	901	1080	14,191	14,465	1820	860	3108	3428	6437	6561	826	390	1410	1555	
87	976	1170	14,597	14,923	1940	860	3271	3618	6621	6769	880	390	1484	1641	

\*Rigging weights are for standard tubes of standard wall thickness (Turbo-B3 and Spikefin 2, 0.025-in. [0.635 mm] wall).

**NOTES:**

1. Cooler includes the control panel (ICVC), suction elbow, and 1/2 the distribution piping weight.
2. Condenser includes float valve and sump, discharge elbow, and 1/2 the distribution piping weight.
3. For special tubes refer to the 19XR/XRV Computer Selection Program.
4. All weights for standard 2-pass NIH (nozzle-in-head) design.

# Physical data (cont)



## ADDITIONAL WEIGHTS FOR 19XR MARINE WATERBOXES\*

### 150 psig (1034 kPa) MARINE WATERBOXES

FRAME	NUMBER OF PASSES	ENGLISH (lb)				SI (kg)			
		Cooler		Condenser		Cooler		Condenser	
		Rigging Wgt	Water Wgt	Rigging Wgt	Water Wgt	Rigging Wgt	Water Wgt	Rigging Wgt	Water Wgt
1	1&3	N/A	N/A	N/A	N/A	N/A	N/A	N/A	N/A
	2	N/A	N/A	N/A	N/A	N/A	N/A	N/A	N/A
2 and 3	1&3	730	700	N/A	N/A	331	318	N/A	N/A
	2	365	350	365	350	166	159	166	159
4	1&3	1888	908	N/A	N/A	856	412	N/A	N/A
	2	944	452	989	452	428	205	449	205
5	1&3	2445	1019	N/A	N/A	1109	462	N/A	N/A
	2	1223	510	1195	499	555	231	542	226
6	1&3	2860	1155	N/A	N/A	1297	524	N/A	N/A
	2	1430	578	1443	578	649	262	655	262
7	1&3	3970	2579	N/A	N/A	1801	1170	N/A	N/A
	2	1720	1290	1561	1025	780	585	708	465
8	1&3	5048	3033	N/A	N/A	2290	1376	N/A	N/A
	2	2182	1517	1751	1172	990	688	794	532

### 300 psig (2068 kPa) MARINE WATERBOXES

FRAME	NUMBER OF PASSES	ENGLISH (lb)				SI (kg)			
		Cooler		Condenser		Cooler		Condenser	
		Rigging Wgt	Water Wgt	Rigging Wgt	Water Wgt	Rigging Wgt	Water Wgt	Rigging Wgt	Water Wgt
1	1&3	N/A	N/A	N/A	N/A	N/A	N/A	N/A	N/A
	2	N/A	N/A	N/A	N/A	N/A	N/A	N/A	N/A
2 and 3	1&3	860	700	N/A	N/A	390	318	N/A	N/A
	2	430	350	430	350	195	159	195	159
4	1&3	2162	908	N/A	N/A	981	412	N/A	N/A
	2	1552	393	1641	393	704	178	744	178
5	1&3	2655	1019	N/A	N/A	1204	462	N/A	N/A
	2	1965	439	1909	418	891	199	866	190
6	1&3	3330	1155	N/A	N/A	1510	524	N/A	N/A
	2	2425	480	2451	480	1100	218	1112	218
7	1&3	5294	2579	N/A	N/A	2401	1170	N/A	N/A
	2	4140	1219	4652	784	1878	553	2110	356
8	1&3	6222	3033	N/A	N/A	2822	1376	N/A	N/A
	2	4952	1343	4559	783	2246	609	2068	355

\*Add to cooler and condenser weights for total weights. Condenser weights may be found in the 19XR Heat Exchanger Weights table on page 11. The first digit of the heat exchanger code (first column) is the heat exchanger frame size.



**19XR WATERBOX COVER WEIGHTS — ENGLISH (lb)  
FRAMES 1, 2, AND 3; COOLER**

WATERBOX DESCRIPTION	COOLER					
	Frame 1		Frame 2		Frame 3	
	Standard Nozzles	Flanged	Standard Nozzles	Flanged	Standard Nozzles	Flanged
NIH, 1 Pass Cover, 150 psig	177	204	282	318	282	318
NIH, 2 Pass Cover, 150 psig	185	218	287	340	287	340
NIH, 3 Pass Cover, 150 psig	180	196	294	310	294	310
NIH Plain End Cover, 150 psig	136	136	243	243	243	243
MWB End Cover, 150 psig	—	—	315	315	315	315
MWB Return Cover, 150 psig	—	—	243	243	243	243
NIH, 1 Pass Cover, 300 psig	248	301	411	486	411	486
NIH, 2 Pass Cover, 300 psig	255	324	411	518	411	518
NIH, 3 Pass Cover, 300 psig	253	288	433	468	433	468
NIH Plain End Cover, 300 psig	175	175	291	291	291	291
MWB End Cover, 300 psig	—	—	619	619	619	619
MWB Return Cover, 300 psig	—	—	445	445	445	445

LEGEND

NIH — Nozzle-in-Head  
MWB — Marine Waterbox

NOTE: Weight for NIH 2-pass cover, 150 psig, is included in the heat exchanger weights shown on page 11.

**FRAMES 1, 2, AND 3; CONDENSER**

WATERBOX DESCRIPTION	CONDENSER					
	Frame 1		Frame 2		Frame 3	
	Standard Nozzles	Flanged	Standard Nozzles	Flanged	Standard Nozzles	Flanged
NIH, 1 Pass Cover, 150 psig	177	204	282	318	282	318
NIH, 2 Pass Cover, 150 psig	185	218	287	340	287	340
NIH, 3 Pass Cover, 150 psig	180	196	294	310	294	310
NIH Plain End Cover, 150 psig	136	136	225	225	225	225
MWB End Cover, 150 psig	—	—	234	234	234	234
MWB Return Cover, 150 psig	—	—	225	225	225	225
NIH, 1 Pass Cover, 300 psig	248	301	411	486	411	486
NIH, 2 Pass Cover, 300 psig	255	324	411	518	411	518
NIH, 3 Pass Cover, 300 psig	253	288	433	468	433	468
NIH Plain End Cover, 300 psig	175	175	270	270	270	270
MWB End Cover, 300 psig	—	—	474	474	474	474
MWB Return Cover, 300 psig	—	—	359	359	359	359

LEGEND

NIH — Nozzle-in-Head  
MWB — Marine Waterbox

NOTE: Weight for NIH 2-pass cover, 150 psig, is included in the heat exchanger weights shown on page 11.

# Physical data (cont)



## 19XR WATERBOX COVER WEIGHTS — ENGLISH (lb) (cont) FRAMES 4, 5, AND 6; COOLER

WATERBOX DESCRIPTION	COOLER					
	Frame 4		Frame 5		Frame 6	
	Standard Nozzles	Flanged	Standard Nozzles	Flanged	Standard Nozzles	Flanged
NIH, 1 Pass Cover, 150 psig	148	185	168	229	187	223
NIH, 2 Pass Cover, 150 psig	202	256	222	276	258	331
NIH, 3 Pass Cover, 150 psig	472	488	617	634	765	791
NIH Plain End Cover, 150 psig	138	138	154	154	172	172
MWB End Cover, 150 psig	314	314	390	390	487	487
MWB Return Cover, 150 psig	138	138	154	154	172	172
NIH, 1 Pass Cover, 300 psig	633	709	764	840	978	1053
NIH, 2 Pass Cover, 300 psig	626	733	760	867	927	1078
NIH, 3 Pass Cover, 300 psig	660	694	795	830	997	1050
NIH/MWB End Cover, 300 psig	522	522	658	658	834	834

LEGEND

NIH — Nozzle-in-Head  
MWB — Marine Waterbox

NOTE: Weight for NIH 2-pass cover, 150 psig, is included in the heat exchanger weights shown on page 11.

## FRAMES 4, 5, AND 6; CONDENSER

WATERBOX DESCRIPTION	CONDENSER					
	Frame 4		Frame 5		Frame 6	
	Standard Nozzles	Flanged	Standard Nozzles	Flanged	Standard Nozzles	Flanged
NIH, 1 Pass Cover, 150 psig	148	185	168	229	187	223
NIH, 2 Pass Cover, 150 psig	191	245	224	298	245	318
NIH, 3 Pass Cover, 150 psig	503	519	628	655	772	799
NIH Plain End Cover, 150 psig	138	138	154	154	172	172
MWB End Cover, 150 psig	314	314	390	390	487	487
MWB Return Cover, 150 psig	138	138	154	154	172	172
NIH, 1 Pass Cover, 300 psig	633	709	764	840	978	1053
NIH, 2 Pass Cover, 300 psig	622	729	727	878	926	1077
NIH, 3 Pass Cover, 300 psig	655	689	785	838	995	1049
NIH/MWB End Cover, 300 psig	522	522	658	658	834	834

LEGEND

NIH — Nozzle-in-Head  
MWB — Marine Waterbox

NOTE: Weight for NIH 2-pass cover, 150 psig, is included in the heat exchanger weights shown on page 11.



**19XR WATERBOX COVER WEIGHTS — ENGLISH (lb) (cont)**  
**FRAMES 7 AND 8; COOLER**

WATERBOX DESCRIPTION	COOLER			
	FRAME 7		FRAME 8	
	Standard Nozzles	Flanged	Standard Nozzles	Flanged
NIH, 1 Pass Cover, 150 psig	329	441	417	494
NIH, 2 Pass Cover, 150 psig	426	541	531	685
NIH, 3 Pass Cover, 150 psig	1250	1291	1629	1687
NIH Plain End Cover, 150 psig	315	315	404	404
MWB End Cover, 150 psig	844	844	1339	1339
MWB Return Cover, 150 psig	315	315	404	404
NIH, 1 Pass Cover, 300 psig	1712	1883	2359	2523
NIH, 2 Pass Cover, 300 psig	1662	1908	2369	2599
NIH, 3 Pass Cover, 300 psig	1724	1807	2353	2516
NIH/MWB End Cover, 300 psig	1378	1378	1951	1951

LEGEND

NIH — Nozzle-in-Head  
MWB — Marine Waterbox

NOTE: Weight for NIH 2-pass cover, 150 psig, is included in the heat exchanger weights shown on page 11.

**FRAMES 7 AND 8; CONDENSER**

WATERBOX DESCRIPTION	CONDENSER			
	Frame 7		Frame 8	
	Standard Nozzles	Flanged	Standard Nozzles	Flanged
NIH, 1 Pass Cover, 150 psig	329	441	417	494
NIH, 2 Pass Cover, 150 psig	404	520	508	662
NIH, 3 Pass Cover, 150 psig	1222	1218	1469	1527
NIH Plain End Cover, 150 psig	315	315	404	404
MWB End Cover, 150 psig	781	781	1007	1007
Bolt On MWB End Cover, 150 PSI	700	700	1307	1307
MWB Return Cover, 150 psig	315	315	404	404
NIH, 1 Pass Cover, 300 psig	1690	1851	1986	2151
NIH, 2 Pass Cover, 300 psig	1628	1862	1893	2222
NIH, 3 Pass Cover, 300 psig	1714	1831	1993	2112
NIH/MWB End Cover, 300 psig	1276	1276	1675	1675

LEGEND

NIH — Nozzle-in-Head  
MWB — Marine Waterbox

NOTE: Weight for NIH 2-pass cover, 150 psig, is included in the heat exchanger weights shown on page 11.

# Physical data (cont)



## 19XR WATERBOX COVER WEIGHTS — SI (kg) FRAMES 1, 2, 3; COOLER

WATERBOX DESCRIPTION	COOLER					
	FRAME 1		FRAME 2		FRAME 3	
	Standard Nozzles	Flanged	Standard Nozzles	Flanged	Standard Nozzles	Flanged
NIH, 1 Pass Cover, 1034 kPa	80	93	128	144	128	144
NIH, 2 Pass Cover, 1034 kPa	84	99	130	154	130	154
NIH, 3 Pass Cover, 1034 kPa	82	89	133	141	133	141
NIH Plain End Cover, 1034 kPa	62	62	110	110	110	110
MWB End Cover, 1034 kPa	—	—	143	143	143	143
MWB Return Cover, 1034 kPa	—	—	110	110	110	110
NIH, 1 Pass Cover, 2068 kPa	112	137	186	220	186	220
NIH, 2 Pass Cover, 2068 kPa	116	147	186	235	186	235
NIH, 3 Pass Cover, 2068 kPa	115	131	196	212	196	212
NIH Plain End Cover, 2068 kPa	79	79	132	132	132	132
MWB End Cover, 2068 kPa	—	—	281	281	281	281
MWB Return Cover, 2068 kPa	—	—	202	202	202	202

### LEGEND

NIH — Nozzle-in-Head

MWB — Marine Waterbox

NOTE: Weight for NIH 2-pass cover, 1034 kPa, is included in the heat exchanger weights shown on page 11.

## FRAMES 1, 2, 3; CONDENSER

WATERBOX DESCRIPTION	CONDENSER					
	Frame 1		Frame 2		Frame 3	
	Standard Nozzles	Flanged	Standard Nozzles	Flanged	Standard Nozzles	Flanged
NIH, 1 Pass Cover, 1034 kPa	80	93	128	144	128	144
NIH, 2 Pass Cover, 1034 kPa	84	99	130	154	130	154
NIH, 3 Pass Cover, 1034 kPa	82	89	133	141	133	141
NIH Plain End Cover, 1034 kPa	62	62	102	102	102	102
MWB End Cover, 1034 kPa	—	—	106	106	106	106
MWB Return Cover, 1034 kPa	—	—	102	102	102	102
NIH, 1 Pass Cover, 2068 kPa	112	137	186	220	186	220
NIH, 2 Pass Cover, 2068 kPa	116	147	186	235	186	235
NIH, 3 Pass Cover, 2068 kPa	115	131	196	212	196	212
NIH Plain End Cover, 2068 kPa	79	79	122	122	122	122
MWB End Cover, 2068 kPa	—	—	215	215	215	215
MWB Return Cover, 2068 kPa	—	—	163	163	163	163

### LEGEND

NIH — Nozzle-in-Head

MWB — Marine Waterbox

NOTE: Weight for NIH 2-pass cover, 1034 kPa, is included in the heat exchanger weights shown on page 11.



**19XR WATERBOX COVER WEIGHTS — SI (kg) (cont)**  
**FRAMES 4, 5, 6; COOLER**

WATERBOX DESCRIPTION	COOLER					
	Frame 4		Frame 5		Frame 6	
	Standard Nozzles	Flanged	Standard Nozzles	Flanged	Standard Nozzles	Flanged
NIH, 1 Pass Cover, 1034 kPa	67	84	76	104	85	101
NIH, 2 Pass Cover, 1034 kPa	92	116	101	125	117	150
NIH, 3 Pass Cover, 1034 kPa	214	221	280	288	347	359
NIH Plain End Cover, 1034 kPa	63	63	70	70	78	78
MWB End Cover, 1034 kPa	142	142	177	177	221	221
MWB Return Cover, 1034 kPa	63	63	70	70	78	78
NIH, 1 Pass Cover, 2068 kPa	287	322	347	381	444	478
NIH, 2 Pass Cover, 2068 kPa	284	332	345	393	420	489
NIH, 3 Pass Cover, 2068 kPa	299	315	361	376	452	476
NIH/MWB End Cover, 2068 kPa	237	237	299	298	378	378

LEGEND

**NIH** — Nozzle-in-Head

**MWB** — Marine Waterbox

NOTE: Weight for NIH 2-pass cover, 1034 kPa, is included in the heat exchanger weights shown on page 11.

**FRAMES 4, 5, 6; CONDENSER**

WATERBOX DESCRIPTION	CONDENSER					
	Frame 4		Frame 5		Frame 6	
	Standard Nozzles	Flanged	Standard Nozzles	Flanged	Standard Nozzles	Flanged
NIH, 1 Pass Cover, 1034 kPa	67	84	76	104	85	101
NIH, 2 Pass Cover, 1034 kPa	87	111	102	135	111	144
NIH, 3 Pass Cover, 1034 kPa	228	235	285	297	350	362
NIH Plain End Cover, 1034 kPa	63	63	70	70	78	78
MWB End Cover, 1034 kPa	142	142	177	177	221	221
MWB Return Cover, 1034 kPa	63	63	70	70	78	78
NIH, 1 Pass Cover, 2068 kPa	287	322	347	381	444	478
NIH, 2 Pass Cover, 2068 kPa	282	331	330	398	420	489
NIH, 3 Pass Cover, 2068 kPa	297	313	356	380	451	476
NIH/MWB End Cover, 2068 kPa	237	237	298	298	378	378

LEGEND

**NIH** — Nozzle-in-Head

**MWB** — Marine Waterbox

NOTE: Weight for NIH 2-pass cover, 1034 kPa, is included in the heat exchanger weights shown on page 11.

# Physical data (cont)



## 19XR WATERBOX COVER WEIGHTS — SI (kg) (cont) FRAMES 7 AND 8; COOLER

WATERBOX DESCRIPTION	COOLER			
	Frame 7		Frame 8	
	Standard Nozzles	Flanged	Standard Nozzles	Flanged
NIH, 1 Pass Cover, 1034 kPa	149	200	189	224
NIH, 2 Pass Cover, 1034 kPa	193	245	241	311
NIH, 3 Pass Cover, 1034 kPa	567	586	739	765
NIH Plain End Cover, 1034 kPa	143	143	183	183
MWB End Cover, 1034 kPa	383	383	607	607
MWB Return Cover, 1034 kPa	143	143	183	183
NIH, 1 Pass Cover, 2068 kPa	777	854	1070	1144
NIH, 2 Pass Cover, 2068 kPa	754	865	1075	1179
NIH, 3 Pass Cover, 2068 kPa	782	820	1067	1141
NIH/MWB End Cover, 2068 kPa	625	625	885	885

### LEGEND

NIH — Nozzle-in-Head

MWB — Marine Waterbox

NOTE: Weight for NIH 2-pass cover, 1034 kPa, is included in the heat exchanger weights shown on page 11.

## FRAMES 7 AND 8; CONDENSER

WATERBOX DESCRIPTION	CONDENSER			
	FRAME 7		FRAME 8	
	Standard Nozzles	Flanged	Standard Nozzles	Flanged
NIH, 1 Pass Cover, 1034 kPa	149	200	189	224
NIH, 2 Pass Cover, 1034 kPa	183	236	230	300
NIH, 3 Pass Cover, 1034 kPa	554	552	666	693
NIH Plain End Cover, 1034 kPa	143	143	183	183
MWB End Cover, 1034 kPa	354	354	457	457
Bolt On MWB End Cover, 1034 kPa	318	318	593	593
MWB Return Cover, 1034 kPa	143	143	183	183
NIH, 1 Pass Cover, 2068 kPa	767	840	901	976
NIH, 2 Pass Cover, 2068 kPa	738	845	859	1008
NIH, 3 Pass Cover, 2068 kPa	777	831	904	958
NIH/MWB End Cover, 2068 kPa	579	579	760	760

### LEGEND

NIH — Nozzle-in-Head

MWB — Marine Waterbox

NOTE: Weight for NIH 2-pass cover, 1034 kPa, is included in the heat exchanger weights shown on page 11.

# Options and accessories



ITEM	OPTION*	ACCESSORY†
Unit-Mounted Variable Frequency Drive	X	X
Shipped Factory Charged with Refrigerant	X	
One, 2, or 3 Pass Cooler or Condenser Waterside Construction	X	
Hot Gas Bypass	X	
Thermal Insulation (Except Waterbox Covers)	X	
Nozzle-in Head Waterbox, 300 psig (2068 kPa)	X	
Marine Waterboxes, 150 psig (1034 kPa)**	X	
Marine Waterboxes, 300 psig (2068 kPa), ASME Certified**	X	
Marine Bolt-On Waterboxes for condenser, 150 psig (1034 kPa) with Cupronickel or Titanium-Clad Tubesheets (Available on Condenser Frame Sizes 3 to 8 Only)**	X	
Flanged Cooler and/or Condenser Waterbox Nozzles††	X	
Waterbox Hinges	X	
Zinc Anodes	X	
0.028 or 0.035 in. (0.711 or 0.889 mm) Internally/Externally Enhanced Copper Tubing — Cooler/Condenser	X	
0.028 or 0.035 in. (0.711 or 0.889 mm) Smooth Bore/Externally Enhanced Copper Tubing — Cooler/Condenser	X	
0.028 or 0.035 in. (0.711 or 0.889 mm) Smooth Bore/Externally Enhanced Cupronickel Tubing — Condenser	X	
0.028 or 0.035 in. (0.711 or 0.889 mm) Internally/Externally Enhanced Cupronickel Tubing — Condenser	X	
0.025 or 0.028 in. (0.635 or 0.711 mm) Wall Tubes, Titanium, Internally Enhanced, Condenser	X	
0.025 or 0.028 in. (0.635 or 0.711 mm) Wall Tubes, Titanium, Smooth Bore, Condenser	X	
Unit-Mounted Low-Voltage Wye-Delta or Solid-State Starters	X	
Export Crating	X	
Customer Factory Performance Testing	X	
Extended Warranty (North America only)	X	
Service Contract	X	
Refrigerant Isolation Valves	X	
Unit-Mounted Pumpout Unit	X	
Seismic Kit	X	
Stand-Alone Pumpout Unit		X
Separate Storage Tank and Pumpout Unit		X
Soleplate Package		X
Sensor Package		X
BACnet*** Communications	X	
LonWorks††† Carrier Translator		X
Discharge Line Sound Reduction Kit		X
Acoustical Sound Insulation Kit		X
Spring Isolator Kit		X

\*Factory Installed.

†Field Installed.

\*\*Optional marine waterboxes available for 19XR heat exchanger frames 2-8 only. Standard waterboxes for both 19XR and 19XRV are nozzle-in-head type, 150 psig (1034 kPa).

††Standard waterbox nozzles are victaulic type. Flanged nozzles are available as an option with either nozzle-in-head type waterboxes or marine waterboxes.

\*\*\*Sponsored by ASHRAE (American Society of Heating, Refrigerating, and Air Conditioning Engineers).

†††Registered trademark of Echelon corporation.

# Options and accessories (cont)



## UNIT-MOUNTED STARTER AND VFD FEATURES AND OPTIONS\*

ITEM	WYE-DELTA	SOLID STATE	VFD
ISM	S	N/A	S
Branch Oil Pump Circuit Breaker	S	S	S
3 kva Controls/Oil Heater Transformer with Branch Circuit Breaker	S	S	S
Microprocessor Based Overload Trip Protection	S	S	S
Main Power Disconnect (Non-Fused Type) with Shunt Trip	S	N/A	N/A
Main Power Circuit Breaker with Shunt Trip	N/A	S	S
High Interrupt Capacity Main Circuit Breaker with Shunt Trip	O	O	O
Phase Loss/Reversal Imbalance Protection	S	S	S
Three Phase Ground Fault Protection†	S	S	S
Integral SCR Bypass Contactor	N/A	S	N/A
Three-Phase Digital Ammeter	S	S	N/A
Three-Phase Analog Ammeter with Switch	O	O	N/A
Three-Phase Digital Voltmeter	S	S	N/A
Three-Phase Analog Voltmeter with Switch	O	O	N/A
Three-Phase Over/Under Voltage Protection	S	S	S
Power Factor Digital Display	S	S	S
Frequency Digital Display	S	S	S
Digital Watt Display	O	O	O
Digital Watt Hour Display	O	O	O
Digital Power Factor Display	O	O	O
Demand Kilowatt Display	O	O	O
Lightning Arrestor and Surge Capacitor Package	O	O	N/A
Power Factor Correction Capacitors	O	O	N/A
Transient Voltage Surge Suppressor	N/A	N/A	S

### LEGEND

**ISM** — Integrated Starter Module  
**N/A** — Not Applicable  
**O** — Optional  
**S** — Standard Feature  
**SCR** — Silicon Control Rectifier  
**VFD** — Variable Frequency Drive

\*Refer to the E-Cat Chiller builder software for all VFD options, as some options may not be available for all VFD models.

†Low voltage: phase to phase and phase to ground. Medium voltage: one phase to phase.

# Dimensions



## 19XR DIMENSIONS (Nozzle-in-Head Waterbox)

HEAT EXCHANGER SIZE	A (Length, with Nozzle-in-Head Waterbox)						19XR B (Width)		19XR C (Height)		19XR V B (Width)		19XR V C (Height)	
	1-Pass		2-Pass*		3-Pass		ft-in.	mm	ft-in.	mm	ft-in.	mm	ft-in.	mm
	ft-in.	mm	ft-in.	mm	ft-in.	mm								
10 to 12	11-11	3632	11-4	3464	11-11	3632	5- 2 <sup>7</sup> / <sub>8</sub>	1597	6- 1 <sup>1</sup> / <sub>4</sub>	1861	5-2 <sup>7</sup> / <sub>8</sub>	1597	7- 3	2210
15 to 17	14- 2 <sup>1</sup> / <sub>2</sub>	4331	13- 7 <sup>1</sup> / <sub>2</sub>	4163	14- 2 <sup>1</sup> / <sub>2</sub>	4331	5- 2 <sup>7</sup> / <sub>8</sub>	1597	6- 1 <sup>1</sup> / <sub>4</sub>	1861	5-2 <sup>7</sup> / <sub>8</sub>	1597	7- 3	2210
20 to 22	12- 0 <sup>1</sup> / <sub>2</sub>	3670	11- 5 <sup>1</sup> / <sub>8</sub>	3483	12- 0 <sup>1</sup> / <sub>2</sub>	3670	5- 6 <sup>7</sup> / <sub>16</sub>	1688	6- 3 <sup>1</sup> / <sub>4</sub>	1911	5-6 <sup>7</sup> / <sub>16</sub>	1688	7- 10 <sup>1</sup> / <sub>4</sub>	2394
30 to 32†	14- 4	4369	13- 8 <sup>5</sup> / <sub>8</sub>	4182	14- 4	4369	5- 7 <sup>3</sup> / <sub>16</sub>	1707	6- 9 <sup>5</sup> / <sub>8</sub>	2073	5-6 <sup>7</sup> / <sub>16</sub>	1688	7- 6 <sup>3</sup> / <sub>4</sub>	2305
30 to 32**	14- 4	4369	13- 8 <sup>5</sup> / <sub>8</sub>	4182	14- 4	4369	5- 7 <sup>3</sup> / <sub>16</sub>	1707	6- 9 <sup>5</sup> / <sub>8</sub>	2073	5-6 <sup>1</sup> / <sub>8</sub>	1680	7- 6 <sup>3</sup> / <sub>4</sub>	2305
35 to 37†	16- 0 <sup>1</sup> / <sub>2</sub>	4889	15- 5 <sup>1</sup> / <sub>8</sub>	4703	16- 0 <sup>1</sup> / <sub>2</sub>	4889	5- 7 <sup>3</sup> / <sub>16</sub>	1707	6- 9 <sup>5</sup> / <sub>8</sub>	2073	5-6 <sup>7</sup> / <sub>16</sub>	1688	7- 6 <sup>3</sup> / <sub>4</sub>	2305
35 to 37**	16- 0 <sup>1</sup> / <sub>2</sub>	4889	15- 5 <sup>1</sup> / <sub>8</sub>	4703	16- 0 <sup>1</sup> / <sub>2</sub>	4889	5- 7 <sup>3</sup> / <sub>16</sub>	1707	6- 9 <sup>5</sup> / <sub>8</sub>	2073	5-6 <sup>1</sup> / <sub>8</sub>	1680	7- 6 <sup>3</sup> / <sub>4</sub>	2305
40 to 42	14- 10	4521	14- 3 <sup>5</sup> / <sub>8</sub>	4360	14- 6 <sup>3</sup> / <sub>4</sub>	4439	6- 3 <sup>1</sup> / <sub>8</sub>	1908	7- 0 <sup>3</sup> / <sub>4</sub>	2153	6- 2	1880	7- 11	2413
45 to 47	16- 6 <sup>1</sup> / <sub>2</sub>	5042	16- 0 <sup>1</sup> / <sub>8</sub>	4880	16- 3 <sup>1</sup> / <sub>4</sub>	4959	6- 3 <sup>1</sup> / <sub>8</sub>	1908	7- 0 <sup>3</sup> / <sub>4</sub>	2153	6- 2	1880	7- 11	2413
50 to 52**	14-11	4546	14- 5	4395	14- 7 <sup>1</sup> / <sub>4</sub>	4451	6- 8 <sup>7</sup> / <sub>8</sub>	2054	7- 2 <sup>3</sup> / <sub>8</sub>	2194	6- 6 <sup>1</sup> / <sub>2</sub>	1994	8- 6 <sup>3</sup> / <sub>4</sub>	2610
50 to 52††	14-11	4546	14- 5	4395	14- 7 <sup>1</sup> / <sub>4</sub>	4451	6- 8 <sup>7</sup> / <sub>8</sub>	2054	7- 2 <sup>3</sup> / <sub>8</sub>	2194	6- 7 <sup>7</sup> / <sub>8</sub>	2029	8- 6 <sup>3</sup> / <sub>4</sub>	2610
5A to 5C	14-11	4546	14- 5	4395	14- 7 <sup>1</sup> / <sub>4</sub>	4451	6- 8 <sup>7</sup> / <sub>8</sub>	2054	7- 2 <sup>3</sup> / <sub>8</sub>	2194	6- 8 <sup>7</sup> / <sub>8</sub>	2054	8- 6 <sup>3</sup> / <sub>4</sub>	2610
55 to 57**	16- 7 <sup>1</sup> / <sub>2</sub>	5067	16- 1 <sup>1</sup> / <sub>2</sub>	4915	16- 3 <sup>3</sup> / <sub>4</sub>	4972	6- 8 <sup>7</sup> / <sub>8</sub>	2054	7- 2 <sup>3</sup> / <sub>8</sub>	2194	6- 6 <sup>1</sup> / <sub>2</sub>	1994	8- 6 <sup>3</sup> / <sub>4</sub>	2610
55 to 57††	16- 7 <sup>1</sup> / <sub>2</sub>	5067	16- 1 <sup>1</sup> / <sub>2</sub>	4915	16- 3 <sup>3</sup> / <sub>4</sub>	4972	6- 8 <sup>7</sup> / <sub>8</sub>	2054	7- 2 <sup>3</sup> / <sub>8</sub>	2194	6- 7 <sup>7</sup> / <sub>8</sub>	2029	8- 6 <sup>3</sup> / <sub>4</sub>	2610
5F to 5H	16- 7 <sup>1</sup> / <sub>2</sub>	5067	16- 1 <sup>1</sup> / <sub>2</sub>	4915	16- 3 <sup>3</sup> / <sub>4</sub>	4972	6- 8 <sup>7</sup> / <sub>8</sub>	2054	7- 2 <sup>3</sup> / <sub>8</sub>	2194	6- 8 <sup>7</sup> / <sub>8</sub>	2054	8- 6 <sup>3</sup> / <sub>4</sub>	2610
60 to 62	15- 0	4572	14- 5 <sup>3</sup> / <sub>4</sub>	4413	14- 7 <sup>3</sup> / <sub>4</sub>	4464	6- 0 <sup>5</sup> / <sub>8</sub>	2124	7- 4 <sup>3</sup> / <sub>8</sub>	2245	6- 10 <sup>5</sup> / <sub>8</sub>	2124	8- 9 <sup>7</sup> / <sub>8</sub>	2689
65 to 67	16- 8 <sup>1</sup> / <sub>2</sub>	5072	16- 2 <sup>1</sup> / <sub>4</sub>	4934	16- 4 <sup>1</sup> / <sub>4</sub>	4985	6- 0 <sup>5</sup> / <sub>8</sub>	2124	7- 4 <sup>3</sup> / <sub>8</sub>	2245	6- 10 <sup>5</sup> / <sub>8</sub>	2124	8- 9 <sup>7</sup> / <sub>8</sub>	2689
70 to 72††	17- 1 <sup>1</sup> / <sub>2</sub>	5219	16-11 <sup>1</sup> / <sub>2</sub>	5169	16-10	5131	7-11 <sup>1</sup> / <sub>2</sub>	2426	9- 9 <sup>1</sup> / <sub>2</sub>	2972	9- 1 <sup>3</sup> / <sub>8</sub>	2778	10	3048
70 to 72***	17- 1 <sup>1</sup> / <sub>2</sub>	5219	16-11 <sup>1</sup> / <sub>2</sub>	5169	16-10	5131	7-11 <sup>1</sup> / <sub>2</sub>	2426	9- 9 <sup>1</sup> / <sub>2</sub>	2972	9- 3 <sup>5</sup> / <sub>8</sub>	2835	10	3048
75 to 77	19- 1 <sup>1</sup> / <sub>2</sub>	5829	18-11 <sup>1</sup> / <sub>2</sub>	5779	18-10	5740	7-11 <sup>1</sup> / <sub>2</sub>	2426	9- 9 <sup>1</sup> / <sub>2</sub>	2972	9- 3 <sup>5</sup> / <sub>8</sub>	2835	10	3048
80 to 82	17- 4 <sup>1</sup> / <sub>2</sub>	5296	17- 1	5205	16- 10 <sup>1</sup> / <sub>2</sub>	5143	8-10 <sup>3</sup> / <sub>4</sub>	2711	9- 11 <sup>1</sup> / <sub>4</sub>	3029	10- 0 <sup>9</sup> / <sub>16</sub>	3063	10	3048
85 to 87	19- 4 <sup>1</sup> / <sub>2</sub>	5905	19- 1	5817	18- 10 <sup>1</sup> / <sub>2</sub>	5753	8-10 <sup>3</sup> / <sub>4</sub>	2711	9- 11 <sup>1</sup> / <sub>4</sub>	3029	10- 0 <sup>9</sup> / <sub>16</sub>	3063	10	3048

\*Assumes both cooler and condenser nozzles on same end of chiller.

†Compressor frame size 2.

\*\*Compressor frame size 3.

††Compressor frame size 4.

\*\*\*Compressor frame size 5.

**NOTES:**

1. Service access should be provided per American Society of Heating, Refrigerating, and Air Conditioning Engineers (ASHRAE) 15, latest edition, National Fire Protection Association (NFPA) 70, and local safety code.
2. Allow at least 3 ft (915 mm) overhead clearance for service rigging for frame 2-4 compressor. Overhead clearance for service rigging frame 5 compressor should be 5 ft (1524 mm).

3. Dimensions are approximate. Certified drawings available upon request.

4. Marine waterboxes may add 6 in. to the width of the machine. See certified drawings for details.

5. 'A' length dimensions shown are for standard 150 psig design and victaulic connections. The 300 psig design and/or flanges will add length. See certified drawings.

6. Not all waterbox/pass combinations are available with unit-mounted VFD. Check selection program and Drawing Manager for availability.

# Dimensions (cont)

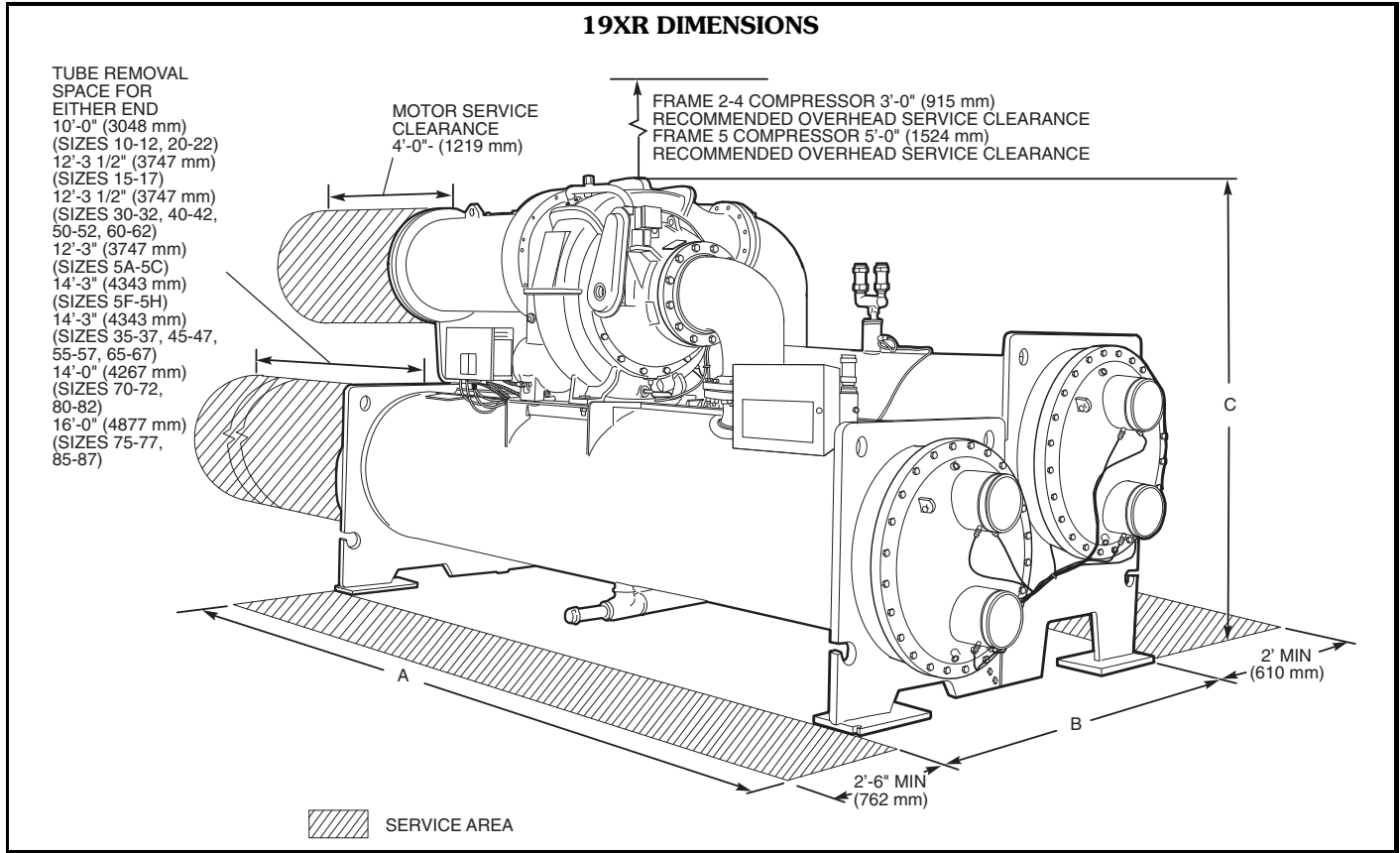

### 19XR DIMENSIONS (Marine Waterbox)

HEAT EXCHANGER SIZE	A (Length, Marine Waterbox)				19XR B WIDTH		19XR.V B WIDTH		19XR.XRV C HEIGHT
	2-Pass*		1 or 3-Pass†		ft-in.	mm	ft-in.	mm	
	ft-in.	mm	ft-in.	mm					
10 to 12	NA	NA	NA	NA	NA	NA	NA	NA	
15 to 17	NA	NA	NA	NA	NA	NA	NA	NA	
20 to 22	12- 5 1/2	3797	14- 1 1/4	4299	6- 1 1/16	1856	6- 1 1/16	1856	
30 to 32	14- 9	4496	16- 4 3/4	4997	6- 1 1/16	1856	6- 1 1/16	1856	
35 to 37	16- 5 1/2	5017	18- 1 1/4	5518	6- 1 1/16	1856	6- 1 1/16	1856	
40 to 42	15- 2 3/4	4642	16- 8 1/4	5086	6- 3 1/4	1911	6- 3 1/4	1911	
45 to 47	16-11 1/4	5163	18- 4 3/4	5607	6- 3 1/4	1911	6- 3 1/4	1911	
50 to 52	15- 3 1/2	4661	16- 8 1/2	5093	6- 8 7/8	2054	6- 8 7/8	2054	
5A to 5C	15- 3 1/2	4661	16- 8 1/2	5093	6- 8 7/8	2054	6- 8 7/8	2054	
55 to 57	17- 0	5182	18- 5	5613	6- 8 7/8	2054	6- 8 7/8	2054	
5F to 5H	17- 0	5182	18- 5	5613	6- 8 7/8	2054	6- 8 7/8	2054	
60 to 62	15- 4 1/8	4677	16- 8 3/4	5099	6-11 3/4	2127	6- 11 3/4	2127	
65 to 67	17- 0 5/8	5197	18- 5 1/4	5620	6-11 3/4	2127	6- 11 3/4	2127	
70 to 72	18- 3 5/8	5579	19- 9 3/4	6039	8- 8 1/8	2645	9- 6 3/8	2905	
75 to 77	20- 3 5/8	6188	21- 9 3/4	6649	8- 8 1/8	2645	9- 6 3/8	2905	
80 to 82	18- 4	5583	19-10 1/2	6058	9- 5 5/8	2886	10- 5	3175	
85 to 87	20- 4	6198	21-10 1/2	6668	9- 5 5/8	2886	10- 5	3175	

See Note 6

\*Assumes both cooler and condenser nozzles on same end of chiller.  
 †1 or 3-pass length applies if cooler is a 1 or 3-pass design.

**NOTES:**

- Service access should be provided per American Society of Heating, Refrigerating, and Air Conditioning Engineers (ASHRAE) 15, latest edition, National Fire Protection Association (NFPA) 70, and local safety code.
- Allow at least 3 ft (915 mm) overhead clearance for service rigging for frame 2-4 compressor. Overhead clearance for service rigging frame 5 compressor should be 5 ft (1524 mm).
- Dimensions are approximate. Certified drawings available upon request.

- Marine waterboxes may add 6 in., to the width of the machine. See certified drawings for details.
- 'A' length dimensions shown are for standard 150 psig design and victaulic connections. The 300 psig design and/or flanges will add length. See certified drawings.
- 19XR.XRV height — check certified drawings.
- Not all waterbox/pass combinations are available with unit-mounted VFD (variable frequency drive). Check selection program for availability.



## NOZZLE SIZE

FRAME SIZE	NOZZLE SIZE (in.) (Nominal Pipe Size)					
	Cooler			Condenser		
	1-Pass	2-Pass	3-Pass	1-Pass	2-Pass	3-Pass
1	8	6	6	8	6	6
2	10	8	6	10	8	6
3	10	8	6	10	8	6
4	10	8	6	10	8	6
5	10	8	6	10	10	8
6	10	10	8	10	10	8
7	14	12	10	14	12	12
8	14	14	12	14	14	12

## Selection procedure

### Compressor motor controllers

Compressor motors, as well as controls and accessories, require the use of starting equipment systems specifically designed for 19XR or 19XRV chillers. Consult your local Carrier representative regarding design information for the selection of starters.

### Capacitors/power factors

Power factor considerations may indicate use of capacitors. Properly sized capacitors improve power factors, especially at part load. The 19XR Computer Selection program can select the proper capacitor size required for the application.

# Electrical data



## AUXILIARY RATINGS (Oil Pump) (3 Phase, 50/60 Hz)

ITEM	AVERAGE kW	MIN/MAX MOTOR VOLTAGE/FREQUENCY V-Ph-Hz	INRUSH kva	SEALED kva
OIL PUMP	1.35	200/240-3-60	9.34	1.65
		380/480-3-60	9.09	1.60
		507/619-3-60	24.38	2.08
	1.50	220/240-3-50	11.15	1.93
		346/440-3-50	8.30	1.76

NOTE: FLA (Full Load Amps) =  $\frac{\text{Sealed kva} \cdot 1000}{\sqrt{3}} \cdot \text{volts}$   
 LRA (Locked Rotor Amps) =  $\frac{\text{Inrush kva} \cdot 1000}{\sqrt{3}} \cdot \text{volts}$

## AUXILIARY RATINGS (Controls, Oil Sump Heater)

ITEM	POWER SUPPLY	SEALED kva	AVERAGE WATTS
CONTROLS	24-vac	0.12	120
OIL SUMP HEATER V-Ph-Hz	115 V or 230 V, Single Phase, 50 or 60 Hz	—	1500 (Frame 2 Compressor)
			1800 (Frame 3,4 Compressor)
			2200 (Frame 5 Compressor)
			1800 (Frame 4 SRD Only)

### LEGEND

SRD — Split Ring Diffuser

### NOTES:

1. Oil sump heater only operates when the compressor is off.
2. Power to oil heater/controls must be on circuits that can provide continuous service when the compressor is disconnected.

## Microprocessor controls

Microprocessor controls provide the safety, interlock, capacity control, and indications necessary to operate the chiller in a safe and efficient manner.

### Control system

The microprocessor control on each Carrier centrifugal system is factory mounted, wired, and tested to ensure machine protection and efficient capacity control. In addition, the program logic ensures proper starting, stopping, and recycling of the chiller and provides a communication link to the Carrier Comfort Network® (CCN) system.

## Features

### Control system

- Component test and diagnostic check
- Programmable recycle allows chiller to recycle at optimum loads for decreased operating costs
- Menu-driven keypad interface for status display, set point control, and system configuration
- CCN compatible
- Primary and secondary status messages
- Individual start/stop schedules for local and CCN operation modes
- Recall of up to 25 alarm/alert messages with diagnostic help
- Two chiller lead/lag with third chiller standby is standard in the PIC II software
- Optional soft stop unloading closes guide vanes to unload the motor to the configured amperage level prior to stopping
- Languages pre-programmed at factory for English, Chinese, Japanese, Korean (ICVC only)
- An ILT (international language translator) is available for conversion of extended ASCII characters

### Safety cutouts

- Bearing oil high temperature\*
- Motor high temperature\*†
- Refrigerant (condenser) high pressure\*†
- Refrigerant (cooler) low temperature\*†
- Lube oil low pressure
- Compressor (refrigerant) discharge temperature\*
- Under voltage\*\*
- Over voltage\*\*
- Oil pump motor overload
- Motor overload†

- Motor acceleration time
- Intermittent power loss
- Compressor starter faults
- Compressor surge protection\*
- Low level ground fault
  - Low voltage — phase to phase and phase to ground
  - Medium voltage — phase to ground
- Cooler freeze protection

### Capacity control

- Leaving chilled water control
- Entering chilled water control
- Ice build control
- Soft loading control by temperature or load ramping
- Guide vane actuator module
- Hot gas bypass valve
- Power (demand) limiter
- Auto. chilled water reset

### Interlocks

- Manual/automatic remote start
- Starting/stopping sequence
  - Pre-lube/post-lube
  - Pre-flow/post-flow
- Compressor starter run interlock
- Pre-start check of safeties and alerts
- Low chilled water (load) recycle
- Monitor/number compressor starts and run hours
- Manual reset of safeties

### Indications

- Chiller operating status message
- Power-on
- Pre-start diagnostic check
- Compressor motor amps
- Pre-alarm alert††
- Alarm
- Contact for remote alarm
- Safety shutdown messages
- Elapsed time (hours of operation)
- Chiller input kW

\*These can be configured by user to provide alert indication at user-defined limit.

†Override protection: Causes compressor to first unload and then, if necessary, shut down.

\*\*Will not require manual reset or cause an alarm if auto-restart after power failure is enabled.

††By display code only.

**CONTROL PANEL DISPLAY (Front View)**  
**ICVC ENGLISH DISPLAY**

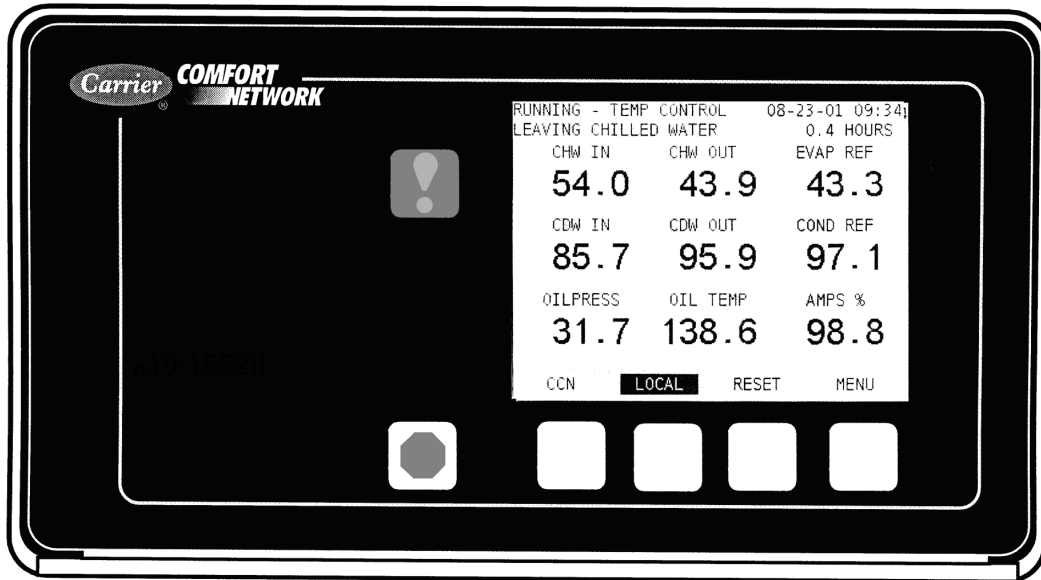

**ICVC KOREAN DISPLAY**

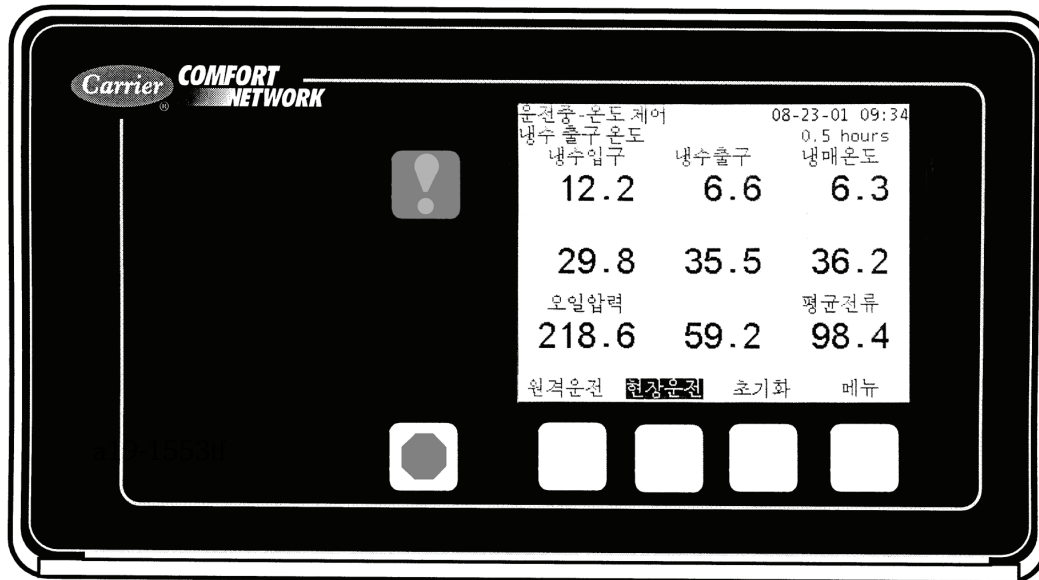

### INSIDE PANEL COVER

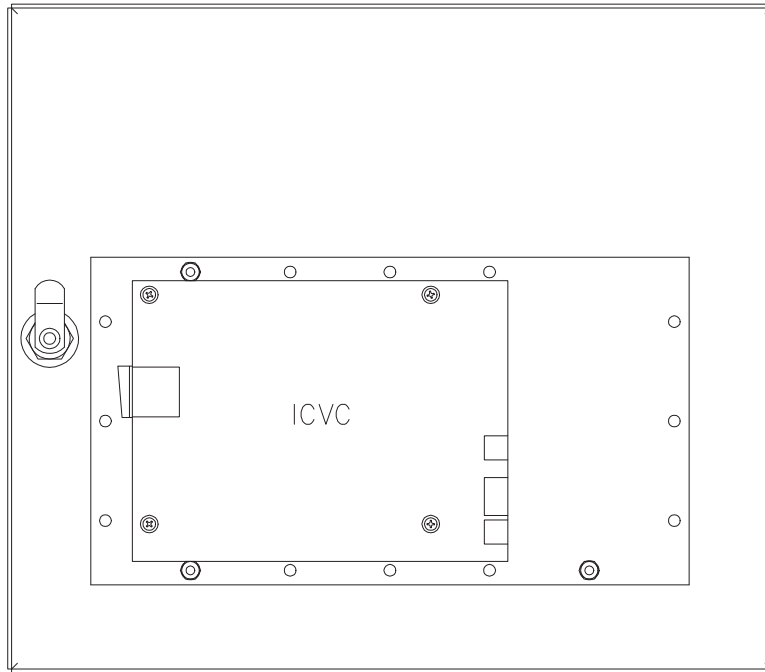

### CONTROL PANEL COMPONENT LAYOUT

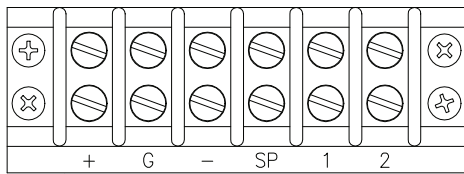

CONTROL PANEL  
TERMINAL BLOCK

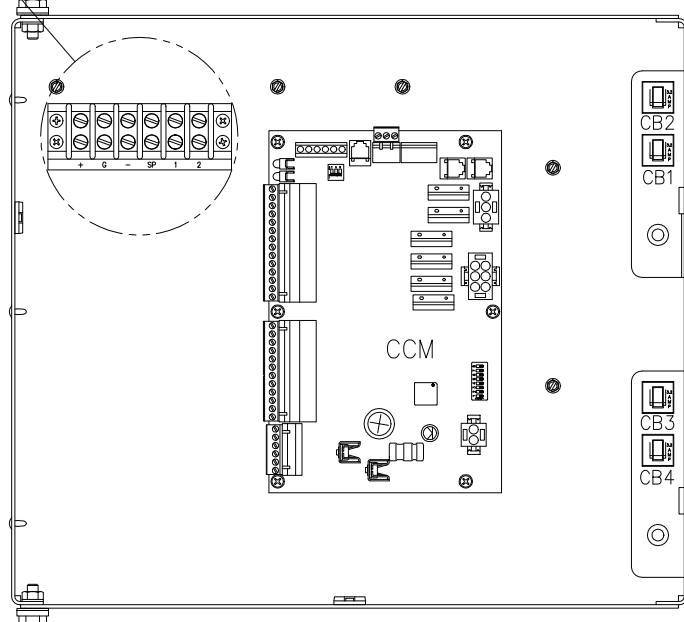

# Typical piping and wiring



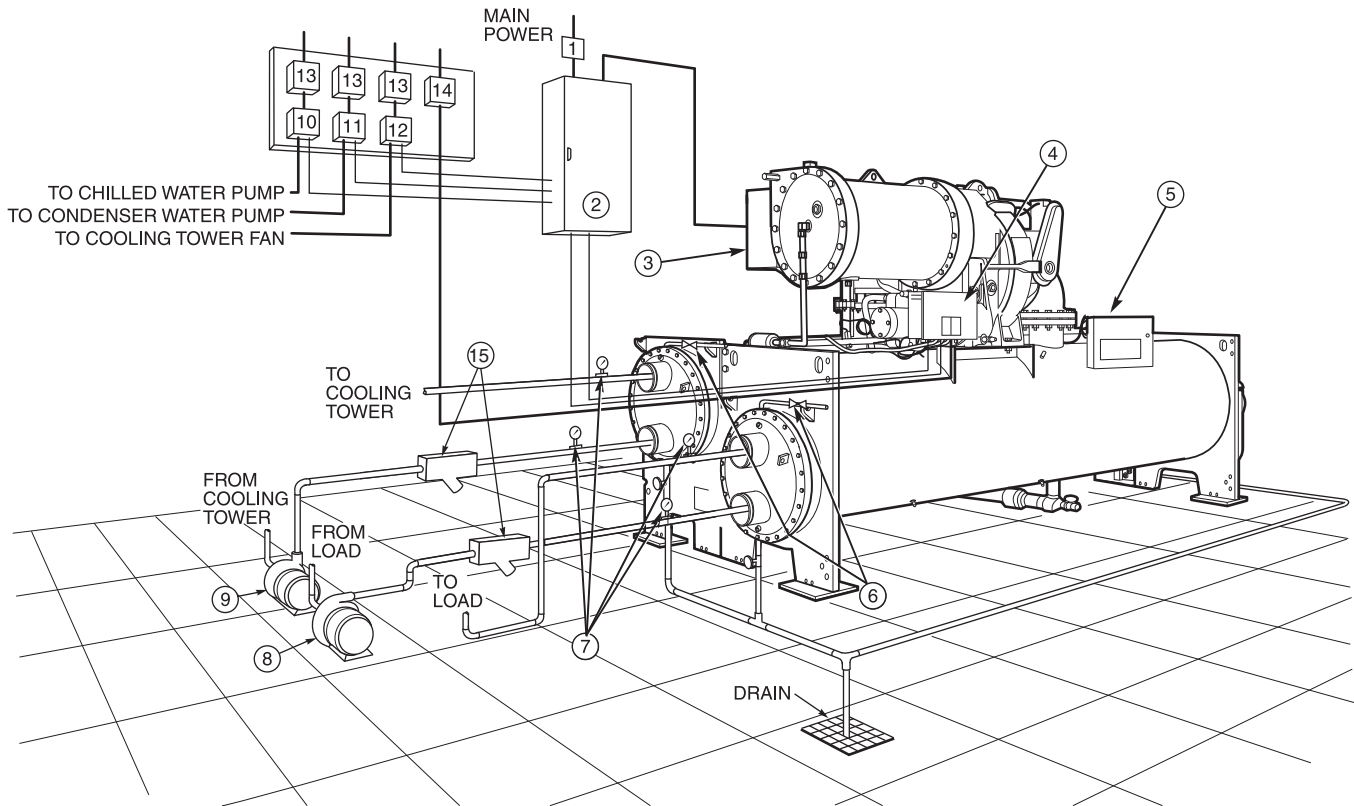

## 19XR CHILLER WITH FREE-STANDING STARTER OR VFD



### LEGEND

- 1 — Disconnect
- 2 — Free-standing Compressor Motor Starter
- 3 — Compressor Motor Terminal Box
- 4 — Power Panel
- 5 — Control Panel
- 6 — Vents
- 7 — Pressure Gages
- 8 — Chilled Water Pump
- 9 — Condenser Water Pump
- 10 — Chilled Water Pump Starter
- 11 — Condensing Water Pump Starter
- 12 — Cooling Tower Fan Starter (Low Fan, High Fan)
- 13 — Disconnect
- 14 — Oil Pump Disconnect (See Note 4)
- 15 — Strainers

-  Piping
-  Control Wiring
-  Power Wiring

### NOTES:

1. Wiring and piping shown are for general point-of-connection only and are not intended to show details for a specific installation. Certified field wiring and dimensional diagrams are available on request.
2. All wiring must comply with applicable codes.
3. Wiring not shown for optional devices such as:
  - Remote Start/Stop
  - Remote Alarms
  - Optional Safety Device
  - 4 to 20 mA Resets
  - Optional Remote Sensors
4. Oil pump disconnect may be located within the enclosure of Item 2 — Free-standing Compressor Motor Starter.

### 19XR CHILLER WITH OPTIONAL UNIT-MOUNTED STARTER OR VFD

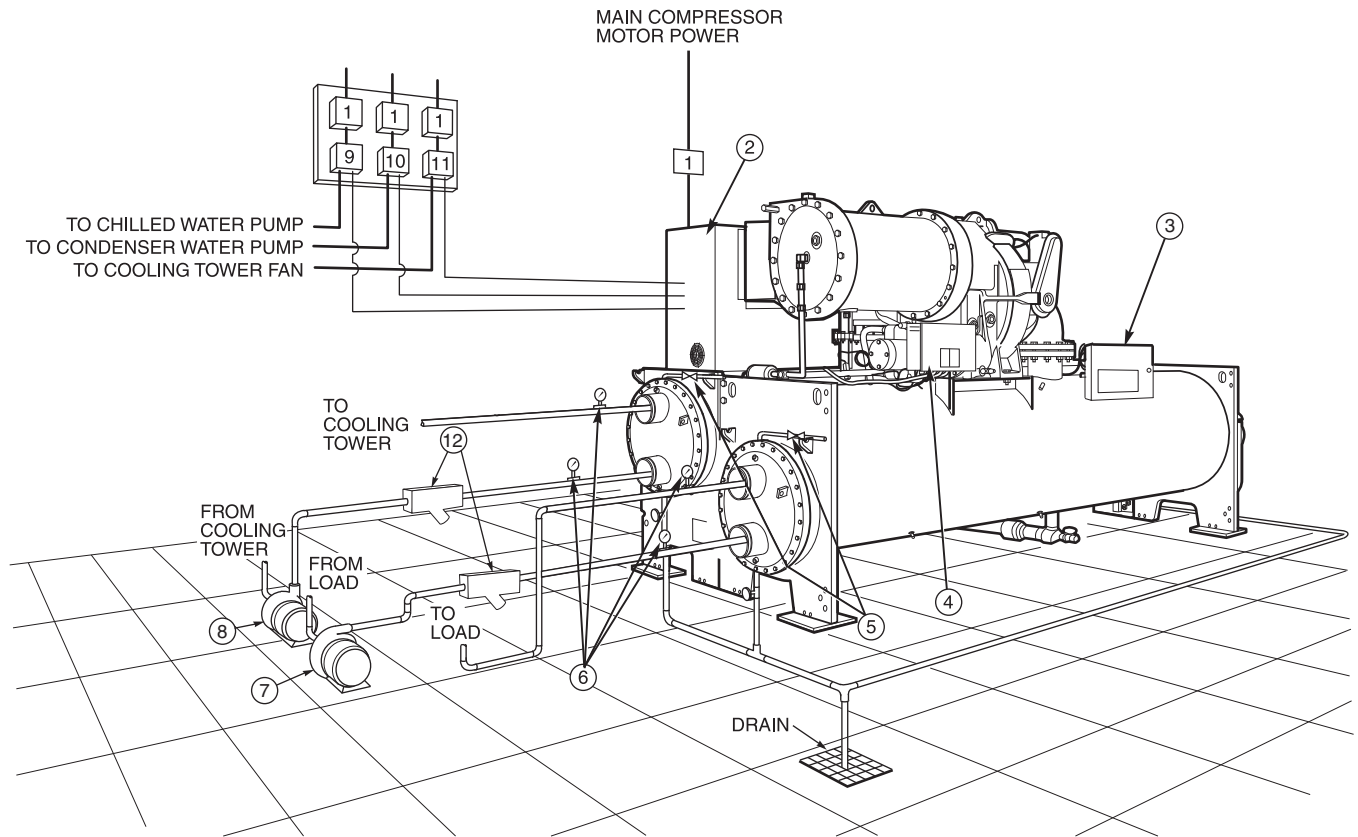

**LEGEND**

- 1 — Disconnect
  - 2 — Unit-Mounted Starter or VFD
  - 3 — Control Panel
  - 4 — Power Panel
  - 5 — Vents
  - 6 — Pressure Gages
  - 7 — Chilled Water Pump
  - 8 — Condenser Water Pump
  - 9 — Chilled Water Pump Starter
  - 10 — Condensing Water Pump Starter
  - 11 — Cooling Tower Fan Starter (Low Fan, High Fan)
  - 12 — Strainers
- Piping  
 Control Wiring  
 Power Wiring

**NOTES:**

1. Wiring and piping shown are for general point-of-connection only and are not intended to show details for a specific installation. Certified field wiring and dimensional diagrams are available on request.
2. All wiring must comply with applicable codes.
3. Wiring not shown for optional devices such as:
  - Remote Start/Stop
  - Remote Alarms
  - Optional Safety Device
  - 4 to 20 mA Resets
  - Optional Remote Sensors

## 19XR,XRV MACHINE FOOTPRINT

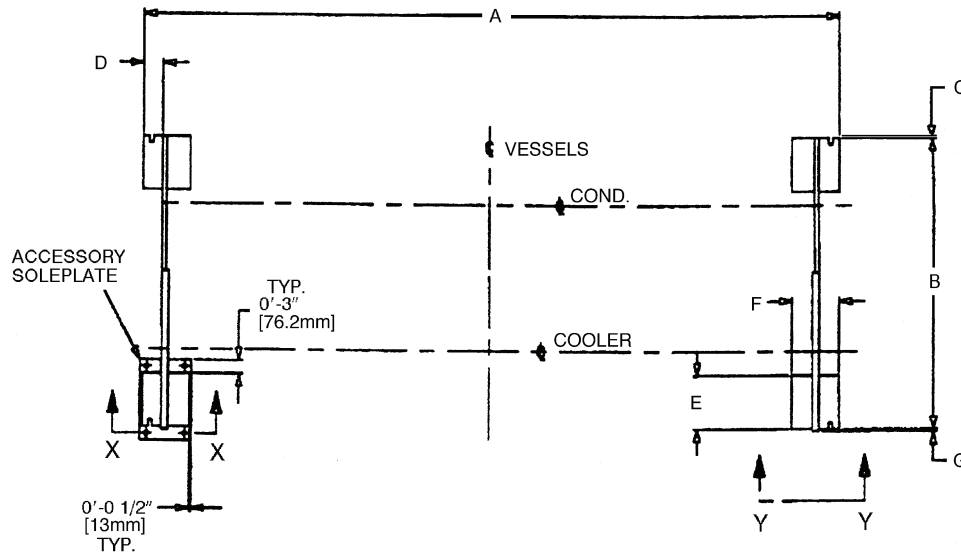

19XR,XRV HEAT EXCHANGER SIZE	DIMENSIONS (ft-in.)						
	A	B	C	D	E	F	G
10-12	10- 7 <sup>1</sup> / <sub>4</sub>	4-10 <sup>1</sup> / <sub>4</sub>	0-1	0-3 <sup>5</sup> / <sub>8</sub>	1- 1 <sup>3</sup> / <sub>4</sub>	0-9	0-1 <sup>1</sup> / <sub>2</sub>
15-17	12-10 <sup>3</sup> / <sub>4</sub>	4-10 <sup>1</sup> / <sub>4</sub>	0-1	0-3 <sup>5</sup> / <sub>8</sub>	1- 1 <sup>3</sup> / <sub>4</sub>	0-9	0-1 <sup>1</sup> / <sub>2</sub>
20-22	10- 7 <sup>1</sup> / <sub>4</sub>	5- 4 <sup>1</sup> / <sub>4</sub>	0-1	0-3 <sup>5</sup> / <sub>8</sub>	1- 1 <sup>3</sup> / <sub>4</sub>	0-9	0-1 <sup>1</sup> / <sub>2</sub>
30-32	12-10 <sup>3</sup> / <sub>4</sub>	5- 4 <sup>1</sup> / <sub>4</sub>	0	0-3 <sup>5</sup> / <sub>8</sub>	1- 1 <sup>3</sup> / <sub>4</sub>	0-9	0-1 <sup>1</sup> / <sub>2</sub>
35-37	14- 7 <sup>1</sup> / <sub>4</sub>	5- 4 <sup>1</sup> / <sub>4</sub>	0	0-3 <sup>5</sup> / <sub>8</sub>	1- 1 <sup>3</sup> / <sub>4</sub>	0-9	0-1 <sup>1</sup> / <sub>2</sub>
40-42	12-10 <sup>3</sup> / <sub>4</sub>	6- 0	0-1 <sup>1</sup> / <sub>2</sub>	0-3 <sup>5</sup> / <sub>8</sub>	1- 1 <sup>3</sup> / <sub>4</sub>	0-9	0-1 <sup>1</sup> / <sub>2</sub>
45-57	14- 7 <sup>1</sup> / <sub>4</sub>	6- 0	0-1 <sup>1</sup> / <sub>2</sub>	0-3 <sup>5</sup> / <sub>8</sub>	1- 1 <sup>3</sup> / <sub>4</sub>	0-9	0-1 <sup>1</sup> / <sub>2</sub>
50-52, 5A-5C	12-10 <sup>3</sup> / <sub>4</sub>	6- 5 <sup>1</sup> / <sub>2</sub>	0- 1 <sup>1</sup> / <sub>2</sub>	0-3 <sup>5</sup> / <sub>8</sub>	1- 1 <sup>3</sup> / <sub>4</sub>	0-9	0-1 <sup>1</sup> / <sub>2</sub>
55-57, 5F-5H	14- 7 <sup>1</sup> / <sub>4</sub>	6- 5 <sup>1</sup> / <sub>2</sub>	0- 1 <sup>1</sup> / <sub>2</sub>	0-3 <sup>5</sup> / <sub>8</sub>	1- 1 <sup>3</sup> / <sub>4</sub>	0-9	0-1 <sup>1</sup> / <sub>2</sub>
60-62	12-10 <sup>3</sup> / <sub>4</sub>	6- 9 <sup>1</sup> / <sub>2</sub>	0- 1 <sup>1</sup> / <sub>2</sub>	0-3 <sup>5</sup> / <sub>8</sub>	1- 1 <sup>3</sup> / <sub>4</sub>	0-9	0-1 <sup>1</sup> / <sub>2</sub>
65-67	14- 7 <sup>1</sup> / <sub>4</sub>	6- 9 <sup>1</sup> / <sub>2</sub>	0- 1 <sup>1</sup> / <sub>2</sub>	0-3 <sup>5</sup> / <sub>8</sub>	1- 1 <sup>3</sup> / <sub>4</sub>	0-9	0-1 <sup>1</sup> / <sub>2</sub>
70-72	15- 1 <sup>7</sup> / <sub>8</sub>	7-10 <sup>1</sup> / <sub>2</sub>	0- 1 <sup>1</sup> / <sub>4</sub>	0-6 <sup>15</sup> / <sub>16</sub>	1-10	1-4	0-3 <sup>3</sup> / <sub>4</sub>
75-77	17- 1 <sup>7</sup> / <sub>8</sub>	7-10 <sup>1</sup> / <sub>2</sub>	0- 1 <sup>1</sup> / <sub>4</sub>	0-6 <sup>15</sup> / <sub>16</sub>	1-10	1-4	0-3 <sup>3</sup> / <sub>4</sub>
80-82	15- 1 <sup>7</sup> / <sub>8</sub>	8- 9 <sup>3</sup> / <sub>4</sub>	0- 1 <sup>5</sup> / <sub>16</sub>	0-6 <sup>15</sup> / <sub>16</sub>	1-10	1-4	0-1 <sup>1</sup> / <sub>16</sub>
85-87	17- 1 <sup>7</sup> / <sub>8</sub>	8- 9 <sup>3</sup> / <sub>4</sub>	0- 1 <sup>5</sup> / <sub>16</sub>	0-6 <sup>15</sup> / <sub>16</sub>	1-10	1-4	0-1 <sup>1</sup> / <sub>16</sub>

## 19XR,XRV ISOLATION WITH ACCESSORY SOLEPLATE PACKAGE

### TYPICAL ISOLATION

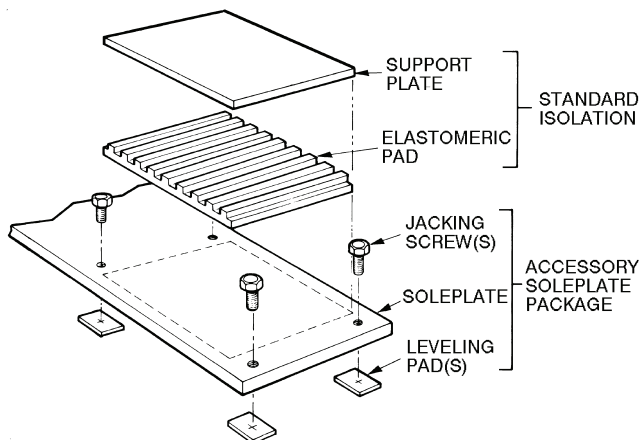

### STANDARD ISOLATION

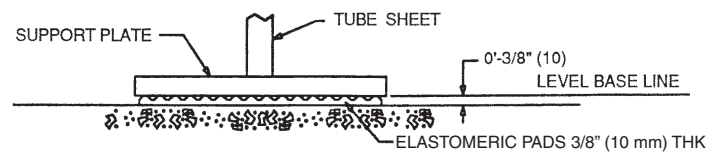

VIEW Y-Y

### ISOLATION WITH ISOLATION PACKAGE ONLY (STANDARD)

NOTE: Isolation package includes 4 Elastomeric pads.

### ACCESSORY SOLEPLATE DETAIL

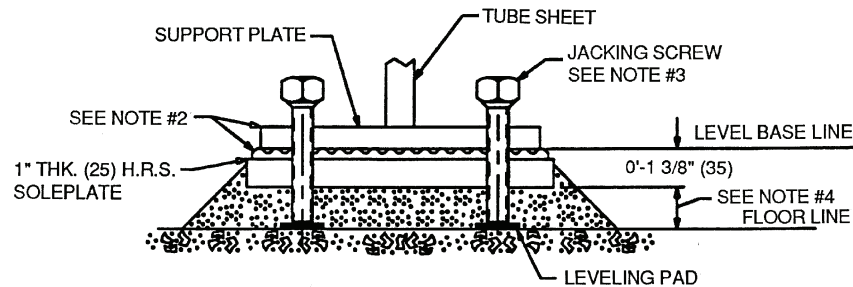

VIEW X-X

#### NOTES:

1. Dimensions in ( ) are in millimeters.
2. Accessory (Carrier supplied, field installed) soleplate package includes 4 soleplates, 16 jacking screws and leveling pads.
3. Jacking screws to be removed after grout has set.
4. Thickness of grout will vary, depending on the amount necessary to level chiller. Use only pre-mixed non-shrinking grout, Masterflow 648 CP-Plus OR Chemrex Embeco 636 Plus Grout, 0'-1½" (38.1) to 0'-2¼" (57) thick.

## 19XR NOZZLE ARRANGEMENTS NOZZLE-IN-HEAD WATERBOXES

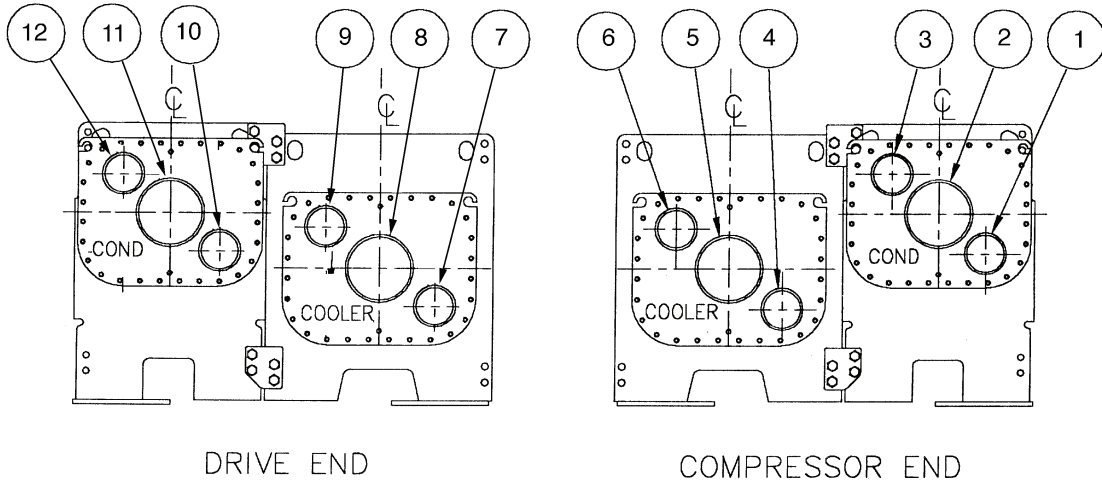

FRAMES 1, 2, AND 3

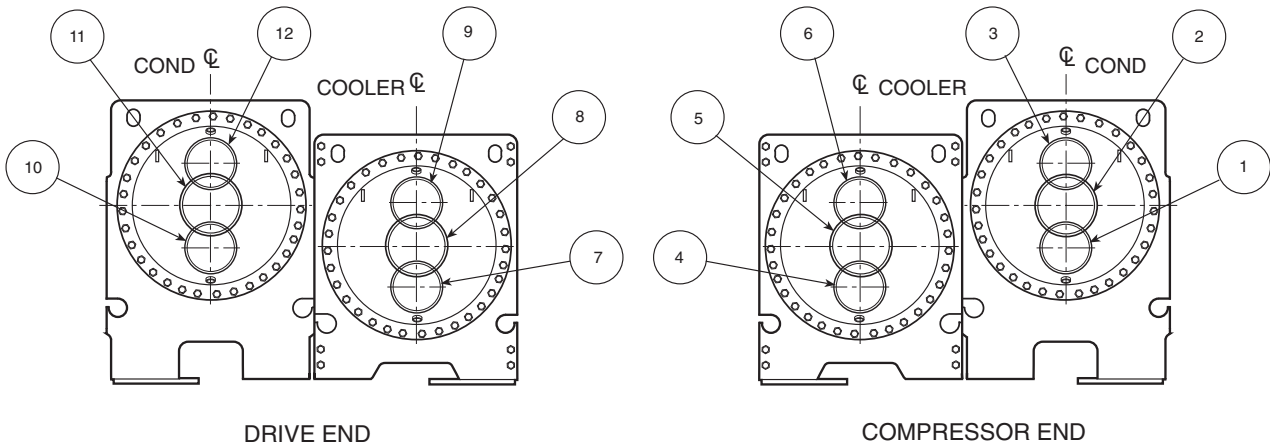

FRAMES 4, 5, AND 6

### 19XR NOZZLE ARRANGEMENTS (cont)

#### NOZZLE-IN-HEAD WATERBOXES (cont)

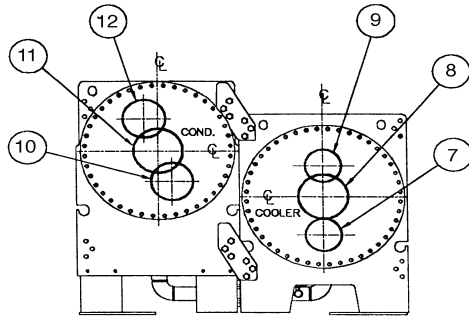

DRIVE END

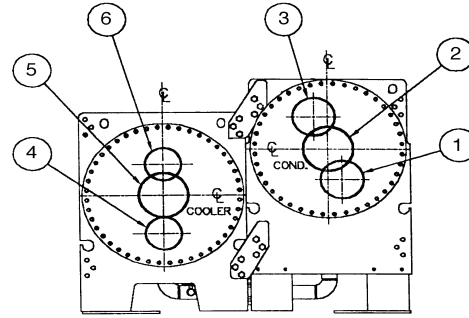

COMPRESSOR END

FRAMES 7 AND 8

#### NOZZLE ARRANGEMENT CODES FOR ALL 19XR NOZZLE-IN-HEAD WATERBOXES

PASS	COOLER WATERBOXES		
	In	Out	Arrangement Code*
1	8	5	A
	5	8	B
2	7	9	C
	4	6	D
3	7	6	E
	4	9	F

PASS	CONDENSER WATERBOXES		
	In	Out	Arrangement Code*
1	11	2	P
	2	11	Q
2	10	12	R
	1	3	S
3	10	3	T
	1	12	U

\*Refer to certified drawings.

#### MARINE WATERBOXES

NOTE :  
COOLER 3-PASS NOZZLE @ 45°  
(NOT SHOWN) SIMILIAR TO  
CONDENSER 2-PASS

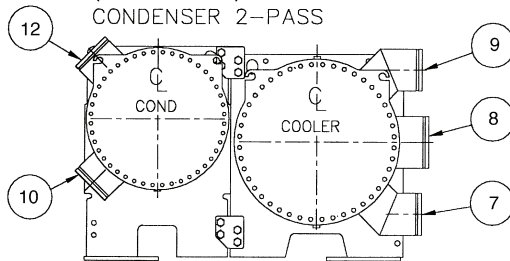

DRIVE END

NOTE :  
COOLER 3-PASS NOZZLE @ 45°  
(NOT SHOWN) SIMILIAR TO  
CONDENSER 2-PASS

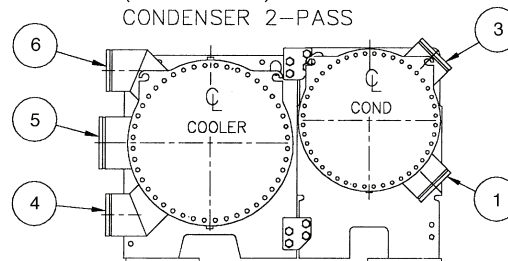

COMPRESSOR END

FRAMES 2 AND 3†

†There is no Frame 1 marine waterbox.

#### NOZZLE ARRANGEMENT CODES

PASS	COOLER WATERBOXES			CONDENSER WATERBOXES		
	In	Out	Arrangement Code	In	Out	Arrangement Code
1	8	5	A	—	—	—
	5	8	B	—	—	—
2	7	9	C	10	12	R
	4	6	D	1	3	S
3	7	6	E	—	—	—
	4	9	F	—	—	—

## 19XR NOZZLE ARRANGEMENTS (cont)

### MARINE WATERBOXES (cont)

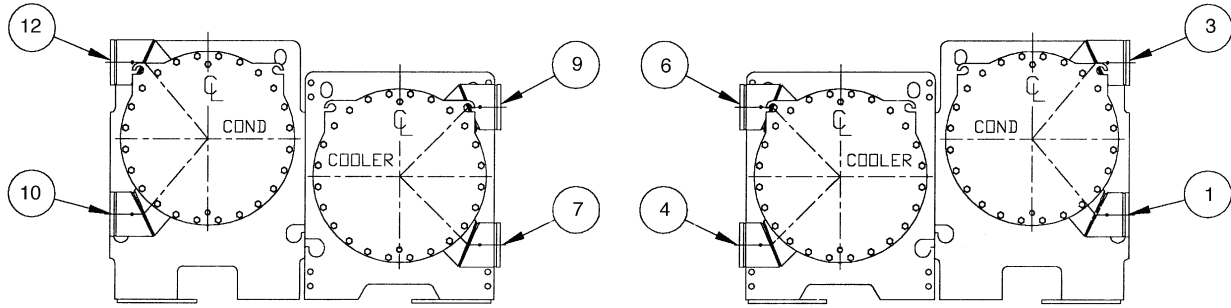

DRIVE END

COMPRESSOR END

FRAMES 4, 5, AND 6

### NOZZLE ARRANGEMENT CODES

PASS	COOLER WATERBOXES			CONDENSER WATERBOXES		
	In	Out	Arrangement Code	In	Out	Arrangement Code
1	9	6	A	—	—	—
	6	9	B	—	—	—
2	7	9	C	10	12	R
	4	6	D	1	3	S
3	7	6	E	—	—	—
	4	9	F	—	—	—

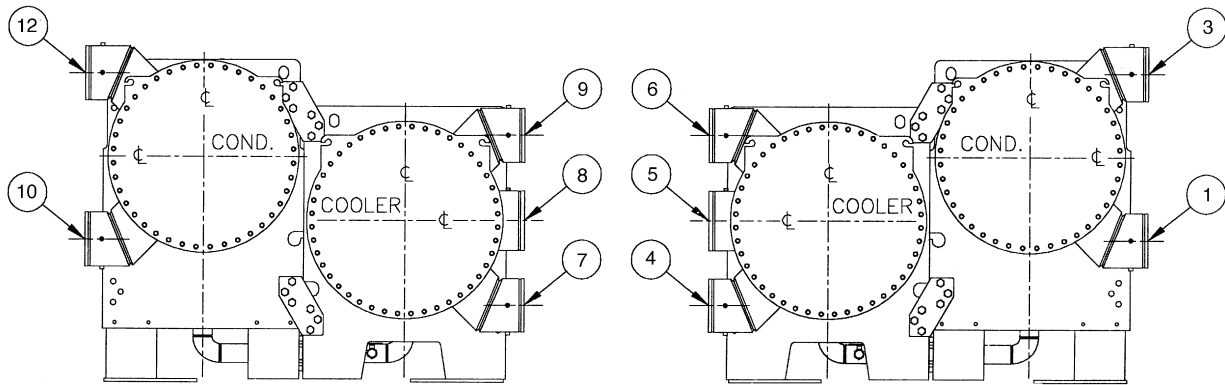

DRIVE END

COMPRESSOR END

FRAMES 7 AND 8

### NOZZLE ARRANGEMENT CODES

PASS	COOLER WATERBOXES			CONDENSER WATERBOXES		
	In	Out	Arrangement Code	In	Out	Arrangement Code
1	8	5	A	—	—	—
	5	8	B	—	—	—
2	7	9	C	10	12	R
	4	6	D	1	3	S
3	7	6	E	—	—	—
	4	9	F	—	—	—



**19XR WATERBOX NOZZLE SIZES (Nozzle-In-Head and Marine Waterboxes)**

FRAME SIZE	PRESSURE psig (kPa)	PASS	NOMINAL PIPE SIZE (in.)		ACTUAL PIPE ID (in.)	
			Cooler	Condenser	Cooler	Condenser
1	150/300 (1034/2068)	1	8	8	7.981	7.981
		2	6	6	6.065	6.065
		3	6	6	6.065	6.065
2	150/300 (1034/2068)	1	10	10	10.020	10.020
		2	8	8	7.981	7.981
		3	6	6	6.065	6.065
3	150/300 (1034/2068)	1	10	10	10.020	10.020
		2	8	8	7.981	7.981
		3	6	6	6.065	6.065
4	150/300 (1034/2068)	1	10	10	10.020	10.020
		2	8	8	7.981	7.981
		3	6	6	6.065	6.065
5	150/300 (1034/2068)	1	10	10	10.020	10.020
		2	8	10	7.981	10.020
		3	6	8	6.065	7.981
6	150/300 (1034/2068)	1	10	10	10.020	10.020
		2	10	10	10.020	10.020
		3	8	8	7.981	7.981
7	150 (1034)	1	14	14	13.250	13.250
		2	12	12	12.000	12.000
		3	10	12	10.020	12.000
	300 (2068)	1	14	14	12.500	12.500
		2	12	12	11.376	11.750
		3	10	12	9.750	11.750
8	150 (1034)	1	14	14	13.250	13.250
		2	14	14	13.250	13.250
		3	12	12	12.000	12.000
	300 (2068)	1	14	14	12.500	12.500
		2	14	14	12.500	12.500
		3	12	12	11.376	11.376

**RELIEF VALVE LOCATIONS**

LOCATION	FRAME SIZE	RELIEF VALVE OUTLET SIZE
COOLER	1-2	1-in. NPT FEMALE CONNECTOR
	3-8	1 1/4-in. NPT FEMALE CONNECTOR
CONDENSER	1-2	1-in. NPT FEMALE CONNECTOR
	3-8	1 1/4-in. NPT FEMALE CONNECTOR
OPTIONAL STORAGE TANK	N/A	1-in. NPT FEMALE CONNECTOR

NOTE: All valves relieve at 185 psig (1275 kPa).

**RELIEF VALVE ARRANGEMENT (Refer to Page 36)**

HEAT EXCHANGER FRAME SIZE	COMPRESSOR FRAME SIZE	WITH/WITHOUT DISCHARGE ISOLATION VALVE	COOLER VIEW	CONDENSER VIEW	COOLER NO. VALVES	CONDENSER NO. VALVES
1, 2	2	With Optional Isolation Valve	A	E	1	2
		Without Optional Isolation Valve	C	E	2	2
3	2	With Optional Isolation Valve	A	E	1	2
		Without Optional Isolation Valve	C	E	2	2
3, 4, 5	3	With Optional Isolation Valve	A	E	1	2
		Without Optional Isolation Valve	C	E	2	2
5, 6	4	With Optional Isolation Valve	A	E	1	2
		Without Optional Isolation Valve	C	E	2	2
7, 8	4, 5	With Optional Isolation Valve	B	F	2	4
		Without Optional Isolation Valve	D	F	4	4

## RELIEF VALVE ARRANGEMENTS

### WITH OPTIONAL ISOLATION OF DISCHARGE AND COOLER

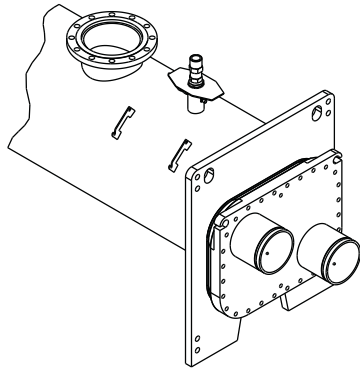

A

FRAME 1-6

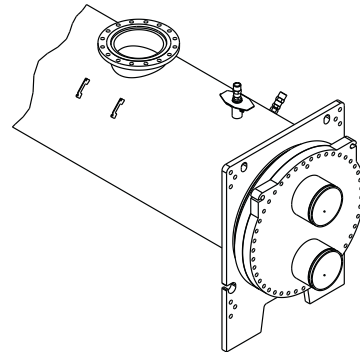

B

FRAME 7, 8

### WITHOUT OPTIONAL ISOLATION OF DISCHARGE AND COOLER

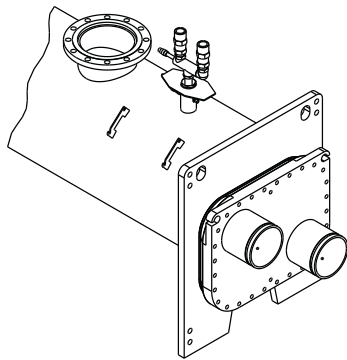

C

FRAME 1-6

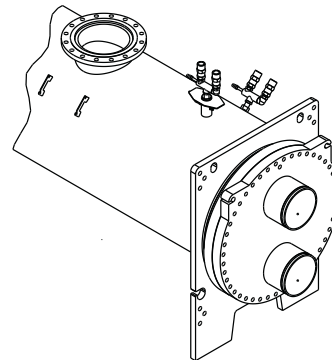

D

FRAME 7, 8

### CONDENSER RELIEF VALVE ARRANGEMENT — WITH OR WITHOUT OPTIONAL ISOLATION

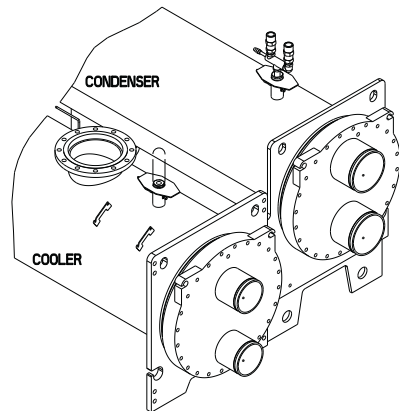

E

FRAME 1-6

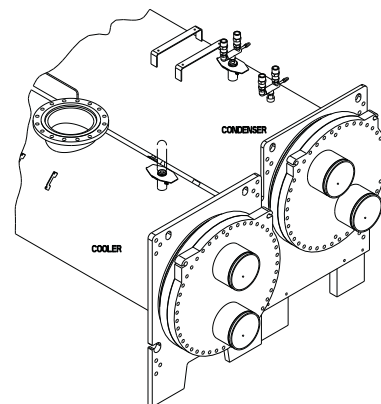

F

FRAME 7, 8



## Vent and drain connections

Nozzle-in head waterboxes have vent and drain connections on covers. Marine waterboxes have vent and drain connections on waterbox shells.

Provide high points of the chiller piping system with vents and the low points with drains. If shutoff valves are provided in the main water pipes near the unit, a minimal amount of system water is lost when the heat exchangers are drained. This reduces the time required for drainage and saves on the cost of re-treating the system water.

It is recommended that pressure gages be provided at points of entering and leaving water to measure pressure drop through the heat exchanger. Gages may be installed as shown in Pressure Gage Location table. Pressure gages installed at the vent and drain connections do not include nozzle pressure losses.

Use a reliable differential pressure gage to measure pressure differential when determining water flow. Regular gages of the required pressure range do not have the accuracy to provide accurate measurement of flow conditions.

### PRESSURE GAGE LOCATION

NUMBER OF PASSES	GAGE LOCATION (Cooler or Condenser)
1 or 3	One gage in each waterbox
2	Two gages in waterbox with nozzles

## ASME stamping

All 19XR heat exchangers are constructed in accordance with ASHRAE (American Society of Heating, Refrigerating, and Air Conditioning Engineers) 15 Safety Code for Mechanical Refrigeration (latest edition). This code, in turn, requires conformance with ASME (American Society of Mechanical Engineers) Code for Unfired Pressure Vessels wherever applicable.

Each heat exchanger is ASME 'U' stamped on the refrigerant side of each vessel.

## Relief valve discharge pipe sizing

See page 35 for number of relief valves and locations.

Relief-valve discharge piping size should be calculated per ASHRAE 15, latest edition, code using the tabulated C factors for each vessel shown in the table below.

### 19XR RELIEF VALVE DISCHARGE PIPE SIZING

HEAT EXCHANGER	FRAME SIZE	VESSEL REQUIRED C FACTOR (lb air/Min)	RELIEF VALVE RATED C FACTOR (lb air/Min)	FIELD CONNECTION SIZE (FPT)
COOLER	10 to 12	30.0	37.6	1"
	15 to 17	36.0	37.6	1"
	20 to 22	35.7	37.6	1"
	30 to 32	43.8	70.8	1 1/4"
	35 to 37	49.9	70.8	1 1/4"
	40 to 42	50.4	70.8	1 1/4"
	45 to 47	57.4	70.8	1 1/4"
	50 to 52, 5A-5C	53.7	70.8	1 1/4"
	55 to 57, 5F-5H	61.1	70.8	1 1/4"
	60 to 62	57.0	70.8	1 1/4"
	65 to 67	64.9	70.8	1 1/4"
	70 to 72	77.0	141.6	1 1/4"
	75 to 77	88.0	141.6	1 1/4"
	80 to 82	87.7	141.6	1 1/4"
85 to 87	100.3	141.6	1 1/4"	
CONDENSER	10 to 12	31.7	40.4	1"
	15 to 17	38.0	40.4	1"
	20 to 22	34.0	37.6	1"
	30 to 32	41.8	70.8	1 1/4"
	35 to 37	47.6	70.8	1 1/4"
	40 to 42	47.1	70.8	1 1/4"
	45 to 47	53.7	70.8	1 1/4"
	50 to 52, 5A-5C	51.2	70.8	1 1/4"
	55 to 57, 5F-5H	58.3	70.8	1 1/4"
	60 to 62	55.3	70.8	1 1/4"
	65 to 67	63.0	70.8	1 1/4"
	70 to 72	72.3	141.6	1 1/4"
	75 to 77	82.7	141.6	1 1/4"
	80 to 82	80.7	141.6	1 1/4"
85 to 87	92.3	141.6	1 1/4"	

Carrier further recommends that an oxygen sensor be installed to protect personnel. Sensor should be able to sense the depletion or displacement of oxygen in the machine room below 19.5% volume oxygen per ASHRAE 15, latest edition.

# Application data (cont)



## Design pressures

Design and test pressures for heat exchangers are listed below.

### DESIGN AND TEST PRESSURES

#### 19XR

PRESSURES	SHELL SIDE (Refrigerant)		STANDARD TUBE SIDE (Water)		OPTIONAL TUBE SIDE (Water)	
	psig	kPa	psig	kPa	psig	kPa
Leak Test at Design Pressure*	185	1276	150	1034	300	2068
Hydrostatic	—	—	195	1344	390	2690
Proof Test*	204	1407	—	—	—	—

\*Nitrogen/Helium.

### HEAT EXCHANGER MATERIAL SPECIFICATIONS

ITEM	MATERIAL	SPECIFICATION
Shell	HR Steel	ASME SA516 GR .70
Tube Sheet	HR Steel	ASME SA516 GR .70
Condenser/Cooler Waterbox Cover	HR Steel	ASME SA516 GR .70, SA-36, or SA-285 GRC
Condenser/Cooler Waterbox Shell	HR Steel	ASME SA675 GR .60, SA-516 GR70, or SA-181 CL70
Tubes	Finned Copper	ASME SB359
Discharge/Suction Pipe	Steel	ASME SA106 GRB
Flanges	Steel	ASME SA105

#### LEGEND

ASME — American Society of Mechanical Engineers  
HR — Hot Rolled

## Insulation

### Factory insulation (optional)

The factory insulation option for the 19XR chiller includes the following areas: cooler (not including waterbox); suction line up to the compressor suction housing; compressor motor and motor cooling return lines; several small oil cooling and oil return system lines, the liquid line, and the float chamber. Optional factory insulation for the 19XR chiller is available for the evaporator shell and tube sheets, suction elbow, compressor motor, motor refrigerant drain line(s) and VFD refrigerant drain lines (19XR units only). Insulation applied at the factory is  $\frac{3}{4}$  in. (19 mm) thick and has a thermal conductivity K value of 0.28 (Btu in.)/hr  $f^2$  °F [(0.0404 • W)/(m • °C)]. Insulation conforms with Underwriters Laboratories (UL) Standard 94, Classification 94HBF.

### MINIMUM FIELD-INSTALLED INSULATION REQUIREMENTS

CHILLER	HEAT EXCHANGER SIZE	INSULATION*	
		ft <sup>2</sup>	m <sup>2</sup>
19XR	10-12	75	6.9
	15-17	85	7.9
	20-22	100	9.3
	30-32	125	11.7
	35-37	135	12.6
	40-42	155	14.4
	45-47	170	15.8
	50-52, 5A-5C	170	15.8
	55-57, 5F-5H	185	17.2
	60-62	185	17.2
	65-67	205	19.1
	70-72	260	24.2
	75-77	295	27.4
	80-82	310	28.8
	85-87	355	32.9

\*Factory installed as shown on page 39.

**Insulation at jobsite** — As indicated in the Condensation vs Relative Humidity table, the factory insulation provides excellent protection against condensation under most operating conditions. If temperatures in the equipment area exceed the maximum design conditions, extra insulation is recommended.

If the machine is to be field insulated, obtain the approximate areas from the Minimum Field-Installed Insulation Requirements table.

Insulation of waterbox is made only in the field and this area is not included in Minimum Field-Installed Insulation Requirements table. When insulating the covers, allow for service access and removal of covers. To estimate waterbox cover areas refer to certified drawings.

High humidity jobsite locations may require field supplied and installed insulation on the float chamber, suction housing, and the lower half of the condenser.

**CONDENSATION VS RELATIVE HUMIDITY\***

AMOUNT OF CONDENSATION	ROOM DRY-BULB TEMP		
	80 F (27 C)	90 F (32 C)	100 F (38 C)
	% Relative Humidity		
None	80	76	70
Slight	87	84	77
Extensive	94	91	84

\*These approximate figures are based on 35 F (1.7 C) saturated suction temperature. A 2° F (1.1° C) change in saturated suction temperature changes the relative humidity values by 1% in the same direction.

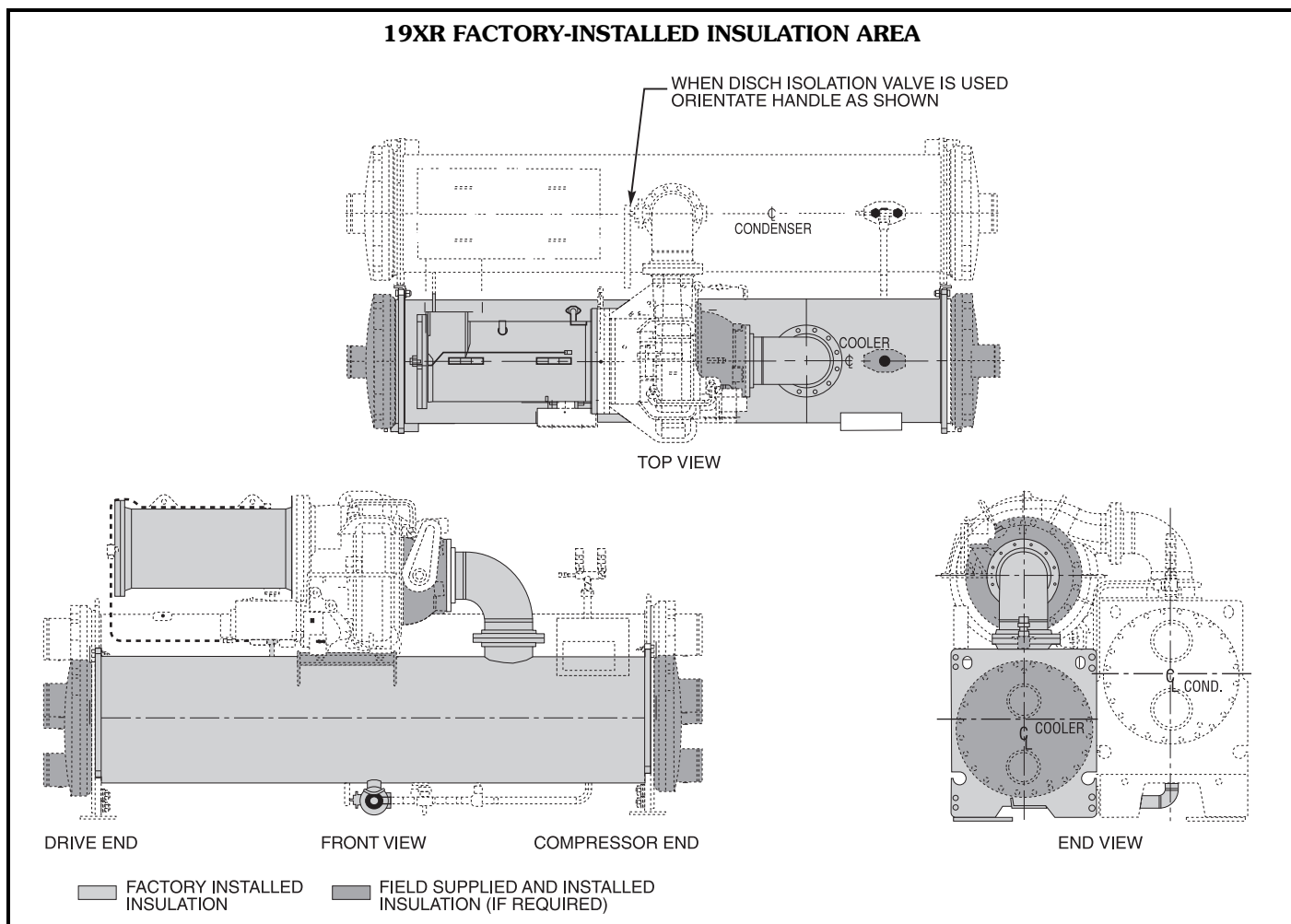

# Guide specifications



## Packaged Hermetic Centrifugal Liquid Chiller

### HVAC Guide Specifications — 19XR, XRV

Size Range:

**19XR — 200 to 1500 Tons (703 to 5275 kW)  
Nominal**

**19XRV — 200 to 1500 Tons (703 to 5275 kW)  
Nominal**

Carrier Model Number:

**19XR, XRV**

### Part 1 — General

#### 1.01 SYSTEM DESCRIPTION

- A. Microprocessor-controlled liquid chiller shall use a single stage, semi-hermetic centrifugal compressor using refrigerant HFC-134a.
- B. If a manufacturer proposes a liquid chiller using HCFC-123 refrigerant, then the manufacturer shall include in the chiller price:
  1. A vapor activated alarm system shall be capable of responding to HCFC-123 levels of 10 ppm Allowable Exposure Limit (AEL).
  2. External refrigerant storage tank and pumpout unit.
  3. Zero emission purge unit capable of operating even when the chiller is not operating.
  4. Back-up relief valve to rupture disk.
  5. Chiller pressurizing system to prevent leakage of noncondensables into chiller during shut-down periods.
  6. Plant room ventilation.

#### 1.02 QUALITY ASSURANCE

- A. Chiller performance shall be rated in accordance with AHRI Standard 550/590, latest edition.
- B. Equipment and installation shall be in compliance with ANSI/ASHRAE 15 (latest edition).
- C. Cooler and condenser refrigerant side shall include ASME “U” stamp and nameplate certifying compliance with ASME Section VIII, Division 1 code for unfired pressure vessels.
- D. Chiller shall be designed and constructed to meet UL and UL, Canada requirements and have labels appropriately affixed.
- E. Centrifugal compressor impellers shall be dynamically balanced and over-speed tested by the manufacturer at a minimum of 120% design operating speed. Each compressor assembly shall undergo a mechanical run-in test to verify vibration levels, oil pressures, and temperatures are within acceptable limits.

Each compressor assembly shall be proof tested at a minimum 204 psig (1406 kPa) and leak tested at 185 psig (1276 kPa) with a tracer gas mixture.

- F. Entire chiller assembly shall be proof tested at 204 psig (1406 kPa) and leak tested at 185 psig (1276 kPa) with a tracer gas mixture on the

refrigerant side. The water side of each heat exchanger shall be hydrostatically tested at 1.3 times rated working pressure.

- G. Prior to shipment, the chiller automated controls test shall be executed to check for proper wiring and ensure correct controls operation.
- H. On chillers with unit-mounted compressor motor starter or VFD (variable frequency drive), the chiller and starter/VFD shall be factory wired and tested together to verify proper operation prior to shipment.

#### 1.03 DELIVERY, STORAGE AND HANDLING

- A. Unit shall be stored and handled in accordance with manufacturer's instructions.
- B. Unit shall be shipped with all refrigerant piping and control wiring factory installed.
- C. Unit shall be shipped charged with oil and full charge of refrigerant HFC-134a or a nitrogen holding charge as specified on the equipment schedule.
- D. Unit shall be shipped with firmly attached labels that indicate name of manufacturer, chiller model number, chiller serial number, and refrigerant used.
- E. If the chiller is to be exported, the unit shall be sufficiently protected from the factory against sea water corrosion to be suitable for shipment in a standard open top, ocean shipping container (19XR, 19XRV heat exchanger frames 1 through 6 only).

#### 1.04 WARRANTY

Warranty shall include parts and labor for one year after start-up or 18 months from shipment, whichever occurs first. A refrigerant warranty shall be provided for a period of five years.

### Part 2 — Products

#### 2.01 EQUIPMENT

##### A. General:

Factory assembled, single piece, liquid chiller shall consist of compressor, motor, starter or variable frequency drive, lubrication system, cooler, condenser, initial oil and refrigerant operating charges, microprocessor control system, and documentation required prior to start-up. An optional compressor motor starter or VFD can be mounted on the chiller, wired, and tested by the chiller manufacturer.

##### B. Compressor:

1. One centrifugal compressor of the high performance, single-stage type.
2. Compressor, motor, and transmission shall be hermetically sealed into a common assembly and arranged for easy field servicing.
3. Internal compressor parts must be accessible for servicing without removing the compressor base from the chiller. Connections to the compressor casing shall use O-rings instead of gaskets to reduce the occurrence of refrigerant leakage. Connections to the compressor shall be flanged or bolted for easy disassembly.



4. All pressure transducers shall have quick disconnects to allow replacement of the sensor without replacement of the entire sensor wire. Pressure transducers shall be capable of field calibration to ensure accurate readings and to avoid unnecessary transducer replacement. Pressure transducers and temperature sensors shall be serviceable without the need for refrigerant charge removal or isolation.
5. Transmission shall be single ratio, single helical, parallel shaft speed increaser. Gears shall conform to AGMA Standards, Quality II.
6. Journal bearings shall be of the steel backed babbitt lined type. Aluminum journal bearings are not acceptable. The thrust bearing shall be tilting pad or rolling element type.
7. Centrifugal compressors shall use variable inlet guide vanes to provide capacity modulation while also providing pre-whirl of the refrigerant vapor entering the impeller for more efficient compression at all loads.
8. Centrifugal compressors shall be provided with a factory-installed lubrication system to deliver oil under pressure to bearings and transmission. Included in the system shall be:
  - a. Hermetic driven rotary vane oil pump with factory-installed motor contactor with overload protection.
  - b. Refrigerant-cooled oil cooler. Water-cooled oil coolers are not acceptable.
  - c. Oil pressure regulator.
  - d. Oil filter with isolation valves to allow filter change without removal of refrigerant charge.
  - e. Oil sump heater controlled from unit microprocessor.
  - f. Oil reservoir temperature sensor with main control center digital readout.
  - g. When factory-mounted compressor motor starter or VFD is provided, all wiring to oil pump, oil heater, and controls shall be pre-wired in the factory.
  - h. Compressor shall be fully field serviceable. Compressors which must be removed and returned to the factory for service shall be unacceptable.

#### C. Motor:

1. Compressor motor shall be of the semi-hermetic, liquid refrigerant cooled, squirrel cage, induction type suitable for voltage shown on the equipment schedule.
2. If an open drive motor is provided, a compressor shaft seal leakage containment system shall be provided:
  - a. An oil reservoir shall collect oil and refrigerant that leaks past the seal.
  - b. A float device shall be provided to open when the reservoir is full, directing the

refrigerant/oil mixture back into the compressor housing.

- c. A refrigerant sensor shall be located next to the open drive seal to detect leaks.
3. Motors shall be suitable for operation in a refrigerant atmosphere and shall be cooled by atomized refrigerant in contact with the motor windings.
4. Motor stator shall be arranged for service or removal with only minor compressor disassembly and without removing main refrigerant piping connections.
5. Full load operation of the motor shall not exceed nameplate rating.
6. One motor winding temperature sensor (and one spare) shall be provided.
7. Should the mechanical contractor choose to provide a chiller with an open motor instead of the specified semi-hermetic motor, the contractor shall install additional cooling equipment to dissipate the motor heat as per the following formula:

$$\text{Btuh} = (\text{FLkW motor}) (0.05) (3413)$$

$$\text{Btuh} = (\text{FLkW motor}) (171)$$

and, alternately

$$\text{Tons} = \text{Btuh} / 12,000$$

The additional piping, valves, air-handling equipment, insulation, wiring, switchgear changes, ductwork, and coordination with other trades shall be the responsibility of the mechanical contractor. Shop drawings reflecting any changes to the design shall be included in the submittal, and incorporated into the final as-built drawings for the project.

8. Also, if an open motor is provided, a mechanical room thermostat shall be provided and set at 104 F (40 C). If this temperature is exceeded, the chillers shall shut down and an alarm signal shall be generated to the central Energy Management System (EMS) display module prompting the service personnel to diagnose and repair the cause of the over temperature condition. The mechanical contractor shall be responsible for all changes to the design, including coordination with temperature control, electrical and other trades. In addition, the electrical power consumption of any auxiliary ventilation and/or mechanical cooling required to maintain the mechanical room conditions stated above shall be considered in the determination of conformance to the scheduled chiller energy efficiency requirement.

#### D. Cooler and Condenser:

1. Cooler shall be of shell and tube type construction, each in separate shells. Units shall be fabricated with high-performance tubing, minimum ¼ inch steel shell and tube sheets with fabricated steel waterboxes.

# Guide specifications (cont)



- a. Waterbox shall be nozzle-in-head waterbox (150 psig).
  - b. Waterbox shall have standard Victaulic grooves.
  2. Condenser shall be of shell and tube type construction, each in separate shells. Units shall be fabricated with high-performance tubing, minimum ¼ inch steel shell and tube sheets with fabricated steel waterboxes.
    - a. Waterbox shall be nozzle-in-head (150 psig).
    - b. Waterbox shall have standard Victaulic grooves.
  3. Waterboxes shall have vents, drains, and covers to permit tube cleaning within the space shown on the drawings. A thermistor type temperature sensor with quick connects shall be factory installed in each water nozzle.
  4. Tubes shall be individually replaceable from either end of the heat exchanger without affecting the strength and durability of the tube sheet and without causing leakage in adjacent tubes.
  5. Tubing shall be copper, high-efficiency type, with integral internal and external enhancement unless otherwise noted. Tubes shall be nominal ¾-in. OD with nominal wall thickness of 0.025 in. measured at the root of the fin at the enhanced areas and nominal wall thickness of 0.049 in. where the tubes are in contact with the end tube sheets unless otherwise noted. Tubes shall be rolled into tube sheets and shall be individually replaceable. Tube sheet holes shall be double grooved for joint structural integrity.
  6. Cooler shall be designed to prevent liquid refrigerant from entering the compressor. Devices that introduce pressure losses (such as mist eliminators) shall not be acceptable because they are subject to structural failures that can result in extensive compressor damage.
  7. The condenser shell shall include a FLASC (Flash Subcooler) which cools the condensed liquid refrigerant to a reduced temperature, thereby increasing the refrigeration cycle efficiency.
  8. A reseating type pressure relief valve shall be installed on each heat exchanger. If a non-reseating type is used, a backup reseating type shall be installed in series.
- E. Refrigerant Flow Control:
- To improve part load efficiency, liquid refrigerant shall be metered from the condenser to the cooler using a float-type metering valve to maintain the proper liquid level of refrigerant in the heat exchangers under both full and part load operating conditions.
- By maintaining a liquid seal at the flow valve, bypassed hot gas from the condenser to the cooler is eliminated. The float valve chamber shall have a bolted access cover to allow field inspection and the float valve shall be field serviceable.
- F. Controls, Safeties, and Diagnostics:
1. Controls:
    - a. The chiller shall be provided with a factory installed and wired microprocessor control center. The control center shall include a 16-line by 40-character liquid crystal display, 4 function keys, stop button, and alarm light. The microprocessor can be configured for either English or SI units.
    - b. All chiller and starter monitoring shall be displayed at the chiller control panel.
    - c. The controls shall make use of non-volatile memory.
    - d. The chiller control system shall have the ability to interface and communicate directly to the building control system.
    - e. The default standard display screen shall simultaneously indicate the following minimum information:
      - 1) date and time of day
      - 2) 24-character primary system status message
      - 3) 24-character secondary status message
      - 4) chiller operating hours
      - 5) entering chilled water temperature
      - 6) leaving chilled water temperature
      - 7) evaporator refrigerant temperature
      - 8) entering condenser water temperature
      - 9) leaving condenser water temperature
      - 10) condenser refrigerant temperature
      - 11) oil supply pressure
      - 12) oil sump temperature
      - 13) percent motor Rated Load Amps (RLA)
    - f. In addition to the default screen, status screens shall be accessible to view the status of every point monitored by the control center including:
      - 1) evaporator pressure
      - 2) condenser pressure
      - 3) bearing oil supply temperature
      - 4) compressor discharge temperature
      - 5) motor winding temperature
      - 6) number of compressor starts
      - 7) control point settings
      - 8) discrete output status of various devices
      - 9) compressor motor starter status
      - 10) optional spare input channels
      - 11) current and voltage for each phase
      - 12) frequency
    - g. Schedule Function:

The chiller controls shall be configurable for manual or automatic start-up and shutdown. In automatic operation mode, the controls shall be capable of automatically starting and stopping the chiller according to a stored user programmable occupancy schedule.

The controls shall include built-in provisions for accepting:

- 1) A minimum of two 365-day occupancy schedules.
- 2) Minimum of 8 separate occupied/unoccupied periods per day.
- 3) Daylight savings start/end.
- 4) 18 user-defined holidays.
- 5) Means of configuring an occupancy timed override.
- 6) Chiller start-up and shutdown via remote contact closure.

h. Service Function:

The controls shall provide a password protected service function which allows authorized individuals to view an alarm history file which shall contain the last 25 alarm/alert messages with time and date stamp. These messages shall be displayed in text form, not codes.

i. Network Window Function:

Each chiller control panel shall be capable of viewing multiple point values and statuses from other like controls connected on a common network, including controller maintenance data. The operator shall be able to alter the remote controller's set points or time schedule and to force point values or statuses for those points that are operator forcible. The control panel shall also have access to the alarm history file of all like controllers connected on the network.

j. Pump Control:

Upon request to start the compressor, the control system shall start the chilled water pump, condenser water pumps and verify that flows have been established.

k. Ramp Loading:

A user-configurable ramp loading rate, effective during the chilled water temperature pulldown period, shall control the rate of guide vane opening to prevent a rapid increase in compressor power consumption. The controls shall allow configuration of the ramp loading rate in either degrees/minute of chilled water temperature pulldown or percent motor amps/minute. During the ramp loading period, a message shall be displayed informing the operator that the chiller is operating in ramp loading mode.

l. Chilled Water Reset:

The control center shall allow reset of the chilled water temperature set point based on any one of the following criteria:

- 1) Chilled water reset based on an external 4 to 20 mA signal.

- 2) Chilled water reset based on a remote temperature sensor (such as outdoor air).
- 3) Chilled water reset based on water temperature rise across the evaporator.

m. Demand Limit:

The control center shall limit amp draw of the compressor to the rated load amps or to a lower value based on one of the following criteria:

- 1) Demand limit based on a user input ranging from 40% to 100% of compressor rated load amps.
- 2) Demand limit based on external 4 to 20 mA signal.

n. Controlled Compressor Shutdown:

The controls shall be capable of being configured to soft stop the compressor. When the stop button is pressed or remote contacts open with this feature active, the guide vanes shall close to a configured amperage level and the machine shall then shut down. The display shall indicate "shutdown in progress."

2. Safeties:

a. Unit shall automatically shut down when any of the following conditions occur: (Each of these protective limits shall require manual reset and cause an alarm message to be displayed on the control panel screen, informing the operator of the shutdown cause.)

- 1) motor overcurrent
- 2) over voltage\*
- 3) under voltage\*
- 4) single cycle dropout\*
- 5) bearing oil high temperature
- 6) low evaporator refrigerant temperature
- 7) high condenser pressure
- 8) high motor temperature
- 9) high compressor discharge temperature
- 10) low oil pressure
- 11) prolonged surge
- 12) loss of cooler water flow
- 13) loss of condenser water flow
- 14) starter fault

\*Shall not require manual reset or cause an alarm if auto-restart after power failure is enabled.

b. The control system shall detect conditions that approach protective limits and take self-corrective action prior to an alarm occurring. The system shall automatically reduce chiller capacity when any of the following parameters are outside their normal operating range:

- 1) high condenser pressure
- 2) high motor temperature
- 3) low evaporator refrigerant temperature

4) high motor amps.

- c. During the capacity override period, a pre-alarm (alert) message shall be displayed informing the operator which condition is causing the capacity override. Once the condition is again within acceptable limits, the override condition shall be terminated and the chiller shall revert to normal chilled water control. If during either condition the protective limit is reached, the chiller shall shut down and a message shall be displayed informing the operator which condition caused the shutdown and alarm.

- d. Internal built-in safeties shall protect the chiller from loss of water flow. Differential pressure switches shall not be allowed to be the only form of freeze protection.

### 3. Diagnostics and Service:

A self diagnostic controls test shall be an integral part of the control system to allow quick identification of malfunctioning components.

Once the controls test has been initiated, all pressure and temperature sensors shall be checked to ensure they are within normal operating range. A pump test shall automatically energize the chilled water pump, condenser water pump, and oil pump. The control system shall confirm that water flow and oil pressure have been established and require operator confirmation before proceeding to the next test. A guide vane actuator test shall open and close the guide vanes to check for proper operation. The operator manually acknowledges proper guide vane operation prior to proceeding to the next test.

In addition to the automated controls test, the controls shall provide a manual test which permits selection and testing of individual control components and inputs. A thermistor test and transducer test shall display on the ICVC (International Chiller Visual Controller) screen the actual reading of each transducer and each thermistor installed on the chiller. All out-of-range sensors shall be identified.

### 4. Multiple Chiller Control:

The chiller controls shall be supplied as standard with a two chiller lead/lag and a third chiller standby system. The control system shall automatically start and stop a lag or second chiller on a two chiller system. If one of the two chillers on line goes into a fault mode, the third standby chiller shall be automatically started. The two chiller lead/lag system shall allow manual rotation of the lead chiller, include load balancing if configured, and a staggered restart of the chillers after a power failure.

### G. Electrical Requirements:

- 1. Electrical contractor shall supply and install main electrical power line, disconnect switches,

circuit breakers, and electrical protection devices per local code requirements and as indicated necessary by the chiller manufacturer.

- 2. Electrical contractor shall wire the chilled water pump, condenser water pump, and tower fan control circuit to the chiller control circuit.
- 3. Electrical contractor shall supply and install electrical wiring and devices required to interface the chiller controls with the building control system if applicable.
- 4. Electrical power shall be supplied to the unit at the voltage, phase, and frequency listed in the equipment schedule.

### H. Piping Requirements — Instrumentation and Safeties:

Mechanical contractor shall supply and install pressure gages in readily accessible locations in piping adjacent to the chiller such that they can be easily read from a standing position on the floor. Scale range shall be such that design values shall be indicated at approximately mid-scale.

Gages shall be installed in the entering and leaving water lines of the cooler and condenser.

#### I. Vibration Isolation:

Chiller manufacturer shall furnish neoprene isolator pads for mounting equipment on a level concrete surface.

#### J. Start-up:

- 1. The chiller manufacturer shall provide a factory-trained representative, employed by the chiller manufacturer, to perform the start-up procedures as outlined in the Start-up, Operation and Maintenance manual provided by the chiller manufacturer.
- 2. Manufacturer shall supply the following literature:
  - a. Start-up, operation and maintenance instructions.
  - b. Installation instructions.
  - c. Field wiring diagrams.
  - d. One complete set of certified drawings.

#### K. Special Features:

- 1. Soleplate Package Accessory:  
Unit manufacturer shall furnish a soleplate package consisting of soleplates, jacking screws, leveling pads, and neoprene pads.
- 2. Spring Isolators Accessory:  
Field furnished and selected for the desired degree of isolation.
- 3. Spare Sensors with Leads Accessory:  
Unit manufacturer shall furnish additional temperature sensors and leads.
- 4. Sound Insulation Kit Accessory:  
Unit manufacturer shall furnish a sound insulation kit that covers (select):
  - a. The compressor discharge pipe.

- b. The compressor housing and motor housing.
  - c. The condenser shell and suction line.  
Blanket construction shall allow for installation and removal without the use of tape or caulk. Insulation material shall be 11 lb/cu ft fiberglass. Insulation design shall accommodate temperature and pressure probes, gages, tubing, piping, and brackets. An extended 2-in. wide vinyl flap shall cover all exposed seams, thereby minimizing any potential noise leaks. An aluminum nameplate shall be riveted to each blanket piece. Each tag shall be embossed or etched with lettering indicating piece location, description, size, and tag number sequence.
5. Stand-Alone Pumpout Unit Accessory:  
A free-standing pumpout shall be provided. The pumpout unit shall use a hermetic reciprocating compressor with water-cooled condenser. Condenser water piping, 3-phase motor power shall be installed at the jobsite by the installing contractor.
  6. Separate Storage Tank and Pumpout Unit Accessory:  
A free-standing refrigerant storage tank and pumpout unit shall be provided. The storage vessels shall be designed per ASME Section VIII Division 1 code with 185 psig (1276 kPa) design pressure. Double relief valves per ANSI/ASHRAE 15, latest edition, shall be provided. The tank shall include a liquid level gage and pressure gage. The pumpout shall use a hermetic reciprocating compressor with water-cooled condenser. Condenser water piping and 3-phase motor power shall be installed at the jobsite by the installing contractor.
  7. Building Control System Interface (LON) Accessory:  
The chiller control system shall have the ability to interface and communicate directly to the building control using a LON-based system. The LonWorks Carrier Translator shall output data in standard LON profiles.
  8. Refrigerant Charge:  
The chiller shall ship from the factory fully charged with R-134a refrigerant and oil.
  9. Thermal Insulation:  
Unit manufacturer shall insulate the cooler shell, economizer low side compressor suction elbow, motor shell and motor cooling lines. Insulation shall be 3/4 in. (19 mm) thick with a thermal conductivity not exceeding 0.28 (Btu in.)/hr ft<sup>2</sup> F and shall conform to UL standard 94, classification 94 HBF.
  10. Automatic Hot Gas Bypass:  
Hot gas bypass valve and piping shall be factory furnished to permit chiller operation for extended periods of time.
  11. Cooler and Condenser Tubes:  
Contact local Carrier representative for other tube offerings.
  12. Cooler and Condenser Passes:  
Unit manufacturer shall provide the cooler and/or condenser with 1, 2 or 3 pass configuration on the water side.
  13. Nozzle-In-Head, 300 psig (2068 kPa):  
Unit manufacturer shall furnish nozzle-in-head style waterboxes on the cooler and/or condenser rated at 300 psig (2068 kPa).
  14. Marine Waterboxes, 150 psig (1034 kPa):  
Unit manufacturer shall furnish marine style waterboxes on cooler and/or condenser rated at 150 psig (1034 kPa).
  15. Marine Waterboxes, 300 psig (2068 kPa):  
Unit manufacturer shall furnish marine style waterboxes on cooler and/or condenser rated at 300 psig (2068 kPa).
  16. Flanged Water Nozzles:  
Unit manufacturer shall furnish standard flanged piping connections on the cooler and/or condenser.
  17. Hinges:  
Unit manufacturer shall furnish hinges on waterboxes to facilitate tube cleaning.
  18. Pumpout Unit:  
A refrigerant pumpout system shall be installed on the chiller. The pumpout system shall include a hermetic compressor and drive, piping, wiring, and motor.
  19. Optional Compressor Discharge Isolation Valve and Liquid Line Ball Valve:  
These items shall be factory installed to allow isolation of the refrigerant charge in the condenser for servicing the compressor.
  20. Optional Seismic Isolation Package:  
Package shall meet International Building Code and ASCE 7 seismic qualification requirements in concurrence with ICC ES AC156 Acceptance Criteria for Seismic Qualification by Shake-Table Testing of Nonstructural Components and Systems. Manufacturer shall provide seismic certificate from OSHPD (California only).
  21. BACnet Communication Option:  
Shall provide factory installed communication capability with a BACnet MS/TP network. Allows integration with i-Vu® Open control system or a BACnet building automation system.
  22. Optional Low-Voltage Unit-Mounted Starter (not available on chiller heat exchanger size 8):  
An optional reduced voltage wye-delta or solid-state starter shall be supplied. The compressor motor starter shall be factory mounted, wired

# Guide specifications (cont)



and tested prior to shipment by the chiller manufacturer. Customer electrical connection for compressor motor power shall be limited to main power leads to the starter, and wiring water pumps and tower fans to the chiller control circuit.

- a. NEMA 1 enclosure with integral fan cooling and lockable hinged doors.
- b. Main power disconnect (non-fused type).
- c. Capability to start and stop chiller, pumps and tower fans.
- d. 3 kva control/oil heater transformer.
- e. Branch circuit breaker to provide power for oil pump.
- f. Branch circuit breaker to provide power for control power and oil heater.
- g. The following standard features:
  - 1) Phase loss
  - 2) Phase reversal
  - 3) Phase imbalance
  - 4) 3-phase ground fault
  - 5) Low voltage — phase to phase and phase to ground
  - 6) Medium voltage — phase to ground
  - 7) Current overload
  - 8) Current flow while stopped
  - 9) 3-phase under/over voltage
  - 10) 3-phase digital ammeter/voltmeter
  - 11) Microprocessor based overload trip protection
  - 12) Frequency
- h. Optional solid-state starter (not available on chiller heat exchanger size 8) shall provide stepless compressor motor acceleration. The starter shall include 6 silicon controlled rectifiers (SCRs) with integrally mounted bypass once the motor has achieved full voltage and speed. The starter shall also display the following:
  - 1) Starter On
  - 2) Run (up to voltage)
  - 3) Phase Correct
  - 4) Over Temperature Fault
  - 5) SCR Gates Energized
  - 6) Ground Fault
  - 7) Current Imbalance Fault
  - 8) Shorted SCR

## 23. Unit-Mounted Variable Frequency Drive (VFD) with Built-in Harmonic Filter (Liqui-Flo™2):

- a. Design:
  - 1) VFD shall be refrigerant cooled, microprocessor based, pulse width modulated (PWM) design. Water-cooled designs are not acceptable.
  - 2) Input and output power devices shall be insulated gate bipolar transistors (IGBTs).

- 3) Active rectifier shall convert incoming voltage / frequency to DC voltage. Input current and voltage shall be regulated.
- 4) Transistorized inverter and control regulator shall convert DC voltage to a sinusoidal PWM waveform.
- 5) Integrated chiller controls shall coordinate motor speed and guide vane position to optimize chiller performance over all chiller operating conditions.
- 6) Surge prevention and surge protection algorithms shall take action to prevent surge and move chiller operation away from surge.

### b. Enclosure:

- 1) Pre-painted unit mounted, NEMA 1 cabinet shall include hinged, lockable doors and removable lifting lugs.
- 2) VFD shall have a short circuit interrupt and withstand rating of at least 65,000 amps (35,000 amps for 575-v units).
- 3) Provisions to padlock main disconnect handle in the "Off" positions shall be provided. Mechanical interlock to prevent opening cabinet door with disconnect in the "On" position or moving disconnect to the "ON" position while the door is open shall be provided.
- 4) Provisions shall be made for top entry of incoming line power cables.

### c. Heat Sink:

- 1) The heat sink shall be refrigerant cooled. Heat sink and mating flange shall be suitable for ASME design working pressure of 185 psig.
- 2) Refrigerant cooling shall be metered by microprocessor control solenoid valve to maintain heat sink temperature within acceptable limits for ambient temperature.
- 3) Water-cooled heat exchangers requiring cleaning shall not be acceptable.

### d. VFD Rating:

- 1) Drive shall be suitable for continuous operation at nameplate voltage  $\pm 10\%$ .
- 2) Drive shall be suitable for continuous operation at 100% of nameplate amps and 150% of nameplate amps for 5 seconds.
- 3) Drive shall comply with applicable ANSI, NEMA, UL and NEC standards.
- 4) Drive shall be suitable for operation in ambient temperatures between 40 and 104 F, 95% humidity (non-condensing) for altitudes up to 6000 feet above sea level. Specific drive performance at jobsite ambient temperature and elevation shall be provided by the manufacturer in the bid.

e. User Interface:

A single display shall provide interface for programming and display of VFD and chiller parameters. Viewable parameters include:

- 1) Operating, configuration and fault messages
- 2) Frequency in hertz
- 3) Load and line side voltage and current (at the VFD)
- 4) kW (line and load side)
- 5) IGBT temperatures

f. VFD Performance:

- 1) VFD Voltage Total Harmonic Distortion (THD) and Harmonic Current Total Demand Distortion (TDD) shall not exceed IEEE-519 requirements using the VFD circuit breaker input terminals as the point of common coupling (PCC).
- 2) VFD full load efficiency shall meet or exceed 97% at 100% VFD Rated Ampacity.
- 3) Active rectifier shall regulate unity displacement power factor to 0.99 or higher at full load.
- 4) Voltage boost capability to provide full motor voltage at reduced line voltage conditions.
- 5) Soft start, linear acceleration, coast to stop.
- 6) Base motor frequency shall be either 50 or 60 hertz. Adjustable frequency range from 39 to 60 hertz or 32.5 to 50 hertz.

g. VFD Electrical Service (single point power):

- 1) VFD shall have input circuit breaker with minimum 65,000 amp interrupt capacity.
- 2) VFD shall have standard 15 amp branch circuit breaker to provide power for chiller oil pump.
- 3) VFD shall have standard 3 kva control power transformer with circuit breaker provides power for oil heater, VFD controls and chiller controls.
- 4) The branch oil pump circuit breaker and control power transformer shall be factory wired.
- 5) Nameplate voltage shall range between 380 to 460  $\pm$ 10 percent, 3 phase, 50/60 Hz,  $\pm$ 2% Hz.

h. Discrete Outputs:

115 v discrete contact outputs shall be provided for field wired:

- 1) Chilled water pump
- 2) Condenser water pump
- 3) Alarm status
- 4) Tower fan low
- 5) Tower fan high

i. Analog Output:

An analog (4 to 20 mA) output for head pressure reference shall be provided. This signal shall be suitable to control a 2-way or 3-way water regulating valve in the condenser piping.

j. Protection (the following shall be supplied):

- 1) Under-voltage
- 2) Over voltage
- 3) Phase loss
- 4) Phase reversal
- 5) Ground fault
- 6) Phase unbalance protection
- 7) Single cycle voltage loss protection
- 8) Programmable auto re-start after loss of power
- 9) Motor overload protection (NEMA Class 10)

k. VFD Testing:

VFD shall be factory mounted, wired and tested on the chiller prior to shipment.

24. Unit-Mounted Variable Frequency Drive (VFD) without Built-In Harmonic Filter:

a. Design:

- 1) VFD shall be refrigerant cooled, micro-processor based, pulse width modulated design. Water cooled designs are not acceptable.
- 2) Output power devices shall be insulated gate bipolar transistors (IGBTs).
- 3) Converter section with full-wave fixed diode bridge rectifier shall convert incoming fixed voltage/frequency to fixed DC voltage.
- 4) DC link shall filter and smooth the converted DC voltage.
- 5) Transistorized inverter and control regulator shall convert fixed DC voltage to a sinusoidal PWM waveform.
- 6) Integrated controls shall coordinate motor speed and guide vane position to optimize chiller performance over a wide variety of operating conditions.
- 7) Surge prevention and surge protection algorithms shall take action to prevent surge and move chiller operation away from surge.

b. Enclosure:

- 1) Pre-painted unit mounted, NEMA 1 cabinet shall include hinged, lockable doors and removable lifting lugs.
- 2) VFD shall have a short circuit interrupt and withstand rating of at least 100,000 amps.
- 3) Provisions to padlock main disconnect handle in the "Off" positions shall be provided. Mechanical interlock to prevent opening cabinet door with disconnect in the "On" position or moving

# Guide specifications (cont)



disconnect to the "ON" position while the door is open shall be provided.

- 4) Provisions shall be made for top entry of incoming line power cables.

## c. Heat Sink:

- 1) The heat sink shall be refrigerant cooled. Heat sink and mating flanges shall be suitable for ASME design working pressure of 185 psig.
- 2) Refrigerant cooling shall be metered by integrated standard controls to maintain heat sink temperature within acceptable limits for ambient temperature.

## d. VFD Rating:

- 1) Drive shall be suitable for nameplate voltage  $\pm 10\%$ .
- 2) Drive shall be suitable for continuous operation at 100% of nameplate amps and 150% of nameplate amps for 3 seconds.
- 3) Drive shall comply with applicable UL, CE, and NEMA standards.
- 4) Drive shall be suitable for operation in ambient temperatures between 40 and 104 F, 95% humidity (non-condensing) for altitudes up to 3300 feet above sea level. Specific drive performance at jobsite ambient temperature and elevation shall be provided by the manufacturer in the bid.

## e. User Interface:

Displays shall provide interface for programming and display of VFD and chiller parameters. Viewable parameters include:

- 1) Operating, configuration and fault messages
- 2) Frequency in hertz
- 3) Load and line side voltage and current (at the VFD)
- 4) kW (on the VFD interface)

## f. VFD Performance:

- 1) VFD full load efficiency shall meet or exceed 97% at 100% VFD Rated Ampacity.
- 2) Displacement Input Power Factor shall meet or exceed 95% soft start, linear acceleration, coast to stop.
- 3) Base motor frequency shall be either 50 or 60 hertz. Adjustable frequency range from 38 to 60 hertz or 32.5 to 50 hertz.

## g. VFD Electrical Service: (single point power):

- 1) VFD shall have input circuit breaker with minimum 100,000 amp interrupt capacity.
- 2) VFD shall have standard 15 amp branch oil pump circuit breaker to provide power for chiller oil pump.
- 3) VFD shall have standard 3 kva control power transformer with circuit breaker provides power for oil heater, VFD controls and chiller controls.
- 4) The branch oil pump circuit breaker and control power transformer shall be factory wired.
- 5) Input power shall be 380/480 vac,  $\pm 10$  percent, 3 phase, 50/60 Hz,  $\pm 3$  Hz.

## h. Discrete Outputs:

115-v discrete contact outputs shall be provided for:

- 1) Circuit breaker shunt trip
- 2) Chilled water pump
- 3) Condenser water pump
- 4) Alarm status.

## i. Analog Output:

An analog (4 to 20 mA) output for head pressure reference shall be provided. This signal shall be suitable to control a 2-way or 3-way water regulating valve in the condenser piping.

## j. Protection (the following shall be supplied):

- 1) Under-voltage
- 2) Over voltage
- 3) Phase loss
- 4) Phase reversal
- 5) Ground fault
- 6) Phase unbalance protection
- 7) Single cycle voltage loss protection
- 8) Programmable auto re-start after loss of power
- 9) Motor overload protection (NEMA Class 10)
- 10) Motor over temperature protection

## k. VFD Testing:

VFD shall be factory mounted, wired and tested on the chiller prior to shipment.

